

# Operating and maintenance manual

## **UNIVERSAL MILLING MACHINE FU 321M**

### **MACHINE TOOL FACTORY**

Arsenal Company, 100 Rozova dolina Str., 6100 Bulgaria  
tel: ++ 359/431/633 22, 634 31 telex 088 507 F ARS BG,  
fax: ++ 359/431/633 32, 631 87  
E-mail: arsenal@arsenal-bg.com  
zmm@arsenal-bg.com



# **UNIVERSAL MILLING MACHINE**

## **FU 321M**

### **SET OF MANUALS:**

**UNIVERSAL MILLING MACHINE FU 321M**  
Operating and Maintenance Manual

**FREQUENCY INVERTOR**  
Operating and Maintenance Manual

**VERTICAL MILLING HEAD VFG 281 / VFG 323**  
Operating and Maintenance Manual

**UNIVERSAL DIVIDING UNIT UDA 125 / UDA 160**  
Operating and Maintenance Manual

**INDEXING TABLE KDM 320**  
Operating and Maintenance Manual

**SLOTING HEAD SG 251 / SG 321**  
Operating and Maintenance Manual

**UNIVERSAL MILLING HEAD UFG 285 / UFG 325**  
Operating and Maintenance Manual

**DIGITAL READING DEVICE**  
Operating and Maintenance Manual

**SYSTEM FOR LUBRICATION**  
Operating and Maintenance Manual

# CONTENTS

CERTIFICATE .....	1
APPLICATION .....	2
SAFETY PRECAUTIONS .....	3
SPECIFICATIONS .....	6
TRANSPORTATION AND INSTALLATION .....	8
PACKING LIST .....	11
TEST CERTIFICATE .....	13
OPERATION .....	15
DESCRIPTION OF THE MAIN MACHINE UNITS .....	19
LUBRICATION .....	21
COOLING SYSTEM .....	22
MAINTENANCE .....	23
LIST OF BEARINGS .....	25
ELECTRIC EQUIPMENT .....	26
DRAWINGS AND CHARTS .....	33

# C E R T I F I C A T E

TYPE: UNIVERSAL MILLING MACHINE  
MODEL: FU 321M

---

Modification:  
normal   
tropical   
metric   
inch

Main motor range:  
standard   
option

Main motor power:  
standard   
option

---

YEAR OF PRODUCTION: .....

SERIAL No: .....

INVENTORY No: .....

## APPLICATION

The Universal Milling Machine is meant to fulfil various milling operations for the needs of general engineering, which are done through circular, disk-type, form end milling, gear and other types of cutters.

Various planes, grooves, gear wheels can be machined, it is capable of boring in steel, cast iron, nonferrous and plastic parts.

The machine can carry out automatic pendulous and semi-automatic linear cycles.

The processing possibilities of the machine can be expanded by using a vertical milling head, an universal milling head, universal indexing device, rotary index table, slotting head, rack toothing device and other accessories.

## SAFETY PRECAUTIONS

Any type of incorrect use of the machine may result in serious personal injury for the machine operator. We suggest therefore that the advice and information offered should be thoroughly digested and adhered to as closely as possible so as to guarantee your safety and for the operator's safety as well as to prolong the life-span of the machine.

### GENERAL PRECAUTIONS

- \* Never leave the machine working without being watched by an operator.
- \* The operator must be trained to operate milling machines. Training should be done by manufacturer's or supplier's expert.
- \* Do not operate this machine without having previously read and fully understood the safety precautions in this chapter.
- \* Do not operate this machine without having previously read and fully understood the Instructions Manual.
- \* Make sure a supervisor or instructor is present the first time you work this machine.
- \* Never attempt to operate the milling machine while your senses are impaired by medication, drugs, alcohol or other substances.
- \* Always use safety gear (safety glasses, shoes, etc.)
- \* Never use gloves which could become caught in the moving parts of the machine i.e. gloves which are too big and/or are damaged. Only use gloves which are in good condition and are the right size for the operator. Gloves should also be used when handling tools / components because they may be sharp.
- \* Always keep the machine and equipment clean.
- \* Do not remove nor modify safety systems or their functioning.
- \* The handle for manual motion of the transversal and vertical feed is to be removed from the machine before putting on the automatic feed and the rapid traverse.
- \* Position yourself at a safe distance from machine so as to avoid getting caught in the moving parts of the machine. Do not wear watches, rings, necklaces, ties, etc. and roll up long sleeves to your elbows, long hair should be tied back.
- \* Provide an adequate light source. If additional lighting is needed do not hesitate in asking for it.
- \* Make sure the network voltage corresponds with the voltage marked on the machine by the manufacturer.

- \* Be aware of the position of the emergency stop.
- \* Protect your hands. Stop the main spindle before proceeding to change tools or workpiece, adjusting a new workpiece, measuring, changing or adjusting belts, pulleys or gears, removing swarf or oil, etc.
- \* Before starting operation make sure that the workpiece and the cutters are well tightened.
- \* Loose objects on the table may be catapulted into the air. Before starting to work remove all loose objects such as tools, mandrels, clothes, etc.
- \* Arrange all tools in order of use.
- \* Damaged or weakened tools break easily. Keep all tools sharp. Check tools and toolholder on a regular basis. Insert the tool as far as possible into the toolholder.
- \* Avoid tool breakage. Use suitable machining feeds and speeds. Reduce speed and feed when unusual noises are noticed. Avoid unnecessary damage to tool and/or workpiece. Never start the machine when the tool is touching the workpiece. After mounting the tool, carry out a trial run. Do not operate the machine in automatic mode in the beginning.
- \* Do not use compressed air to clean or remove dust and swarf from the machine and its surroundings. Use a brush or chip scraper.
- \* Certain materials, such as magnetisium are highly inflammable in powder or chip form. Always consult a supervisor before working with these materials.
- \* Prevent fires. Keep inflamable material and liquid well away from the work area and hot swarf.
- \* Make sure the machine is disconnected from the mains before procceding with any type of repairs or maintenance.
- \* Maintenance should be carried out by qualified staff.

**WARNING:** All electrical connections must be performed by a qualified electrician or service engineer.

THIS DOCUMENT IS A GUIDELINE FOR THE OPERATOR. HOWEVER, "ARSENAL" Co. DOES NOT ASSUME ANY RESPONSIBILITY FOR ANY ACCIDENTS NOR CAN WE GUARANTEE THE AVOIDANCE OF ANY ACCIDENTS EVEN IF ALL SAFETY INSTRUCTIONS ARE STRICTLY FOLLOWED AS THE TYPE OF WORK PERFORMED MAY REQUIRE DIFFERENT SAFETY MEASURES.

## NOISE OUTPUT LEVEL DETAILS

In accordance with paragraph (1.7.4.f) of APPENDIX I of the 98/37/EG Directive we hereafter state the noise output values for the machine:

- 1) acoustic pressure level value at idle running of main drive at max. speed - ..... dB
- 2) acoustic pressure level value when cutting - less than 82 dB

### Fact gathering system:

Measuring of the acoustic pressure has taken place at 1 meter from the machine and a height of 1.60 meter above the floor.



## SPECIFICATIONS

### Basic dimensions

Distance from spindle center to table top		
minimum .....	mm	30
maximum .....	mm	490
Distance between body guides and table center		
minimum .....	mm	280
maximum .....	mm	640
Distance from spindle center to yoke .....	mm	150
Distance from floor to spindle center .....	mm	1430

### Table

Working table size .....	mm	320 x 1350
Table swing to left and right .....	degrees	≤ 45
Table travel:		
- longitudinal		
manual .....	mm	1000
automatic .....	mm	980
- cross		
manual .....	mm	360
automatic .....	mm	340
- vertical		
manual .....	mm	460
automatic .....	mm	440
T-slots .....	No	5
T-slot width .....	mm	18
Distance between T-slots .....	mm	63
Table feeds .....	No	stepless
Feed range		
longitudinal .....	mm/min	10 - 1000
cross .....	mm/min	10 - 1000
vertical .....	mm/min	4 - 415

rapid traverse			
longitudinal .....	mm/min	2500	
cross .....	mm/min	2500	
vertical .....	mm/min	1040	

### Spindle

Spindle nose .....	ISO	50	
Spindle bore .....	mm	29	
Spindle dia at front bearing .....	mm	110	
No. of spindle speeds .....	No	18	
Spindle speed range			
standard .....	min <sup>-1</sup>	32 - 1600	
option .....	min <sup>-1</sup>	40 - 2000	

### Drive

Main motor power:			
standart .....	kW	7,5	
option .....	kW	5,5	
Feed motor power .....	kW	2,2	

### Overall dimensions:

Length .....	mm	2620	
Width .....	mm	2090	
Height .....	mm	1780	
Machine weight .....	kg	2850	

## TRANSPORTATION AND INSTALLATION

### LIFTING, MOVING AND TRANSPORTATION

When the machine is in packed condition, it should be lifted and moved to the transport vehicle by means of a lifting equipment of more than 4 t capacity, being gripped at the place indicated on the packing / Fig.23 /.

When the machine is in unpacked condition or is in a packing, suitable for truck transportation (just on a pallet), it should be lifted and moved as slings are fixed on the yoke. Protection pads 10 / Fig.1 / are put under the slings to protect the finished surfaces. The yoke should be locked.

### UNPACKING

During unpacking the availability of all parts and accessories should be established according to the packing list. Claims, related to shortages and condition of the machine and its accessories, made after putting it into operation, are not accepted.

### CLEANING

Before machine installation, it should be cleaned from the rust - preventing oil with pure diesel oil. For removal of protective oil film, do not use solid objects and diluents that can damage the metal surfaces, paint and label marking. The following water-soluble alkaline degreasing materials are recommended:

- Flexiclean and Techniclean, manufactured by CASTROL;
- Cimclean PC 410 and Cimclean PC 430, manufactured by CIMCOOL

Unpainted surfaces should be dried with rags and then lubricated with "Mobil Vactra oil No.2". The machine mechanisms shall be lubricated after installation and foundation as specified in section "Lubrication".

### FOUNDATION

The location of the machine must be picked carefully. A minimum distance of 500 mm must be left between the machine and any other machine and/or structures. Do not place the machine in a humid, dirty and badly illuminated environment.

While foundation is being done, check regularly the longitudinal and cross levelling of the work table. The tolerance is 0.03 mm per 1000 mm. Levelling accuracy can be achieved with the help of wedges positioned near the foundation bolts.

Install the machine on stable and flat concrete floor and if necessary use additional pads including vibroinsulating pads, or place concrete. If the floor is unstable, install the machine on a concrete foundation / Fig.2 /. Machine base has holes for the foundation bolts, by which machine can be fixed at special situations. The dimension H depends on the bearing capacity of the soil, but it should be minimum 350 mm.

After final curing of the concrete, tight the nuts of foundation bolts (if used), as continuously observe and keep not to disturb the horizontal leveling of the machine. Then fill the space between the machine and the foundation with a mixture of sand and cement.

Foundation bolts, nuts and the leveling plates are not delivered by the producer.

**NOTE:** The use of vibration insulating supports is allowed if the soil is hard enough. Foundation bolts, nuts and wedges are not supplied by the manufacturer.

## MACHINE DIMENSIONS

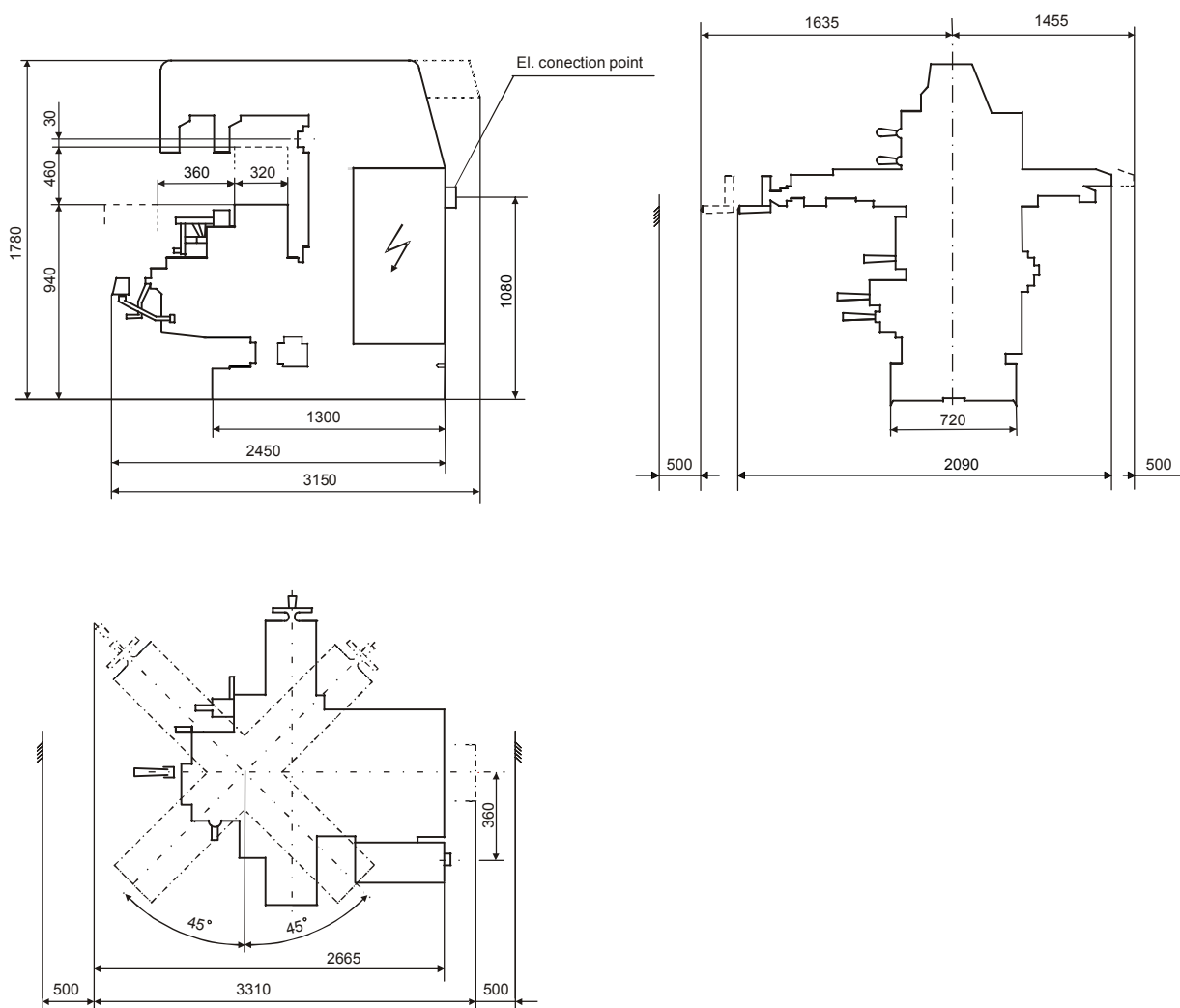

## FITTING OF THE TABLE GUARDS

The purpose of this safety system is to protect the operator when the machine is performing any kind of operation and at same time to give the opportunity of safety observation of the working process.

Polymethyl-methacrylate (CRYSTACRYL 4 mm) is used for transparent parts of this device. If any transparent part (a door or a panel) become scratched or damaged in any way it should be replaced for safety reasons. This parts should be cleaned regularly to avoid the operator's view obstruction.

The safety guard consists of 2 front doors and 2 side panels. Before proceeding with any kind of operation the both front doors should be closed.

The fitting of the table guards is done by M8 bolts on both sides of the working table keyways as shown below. First close both doors and then tighten the bolts fully.

**NOTE:** The machines are being delivered with mounted safety guards.

**OPTIONAL:** An interlock system can be fitted to table guards. To fit the interlock guard switch to the electrical cabinet, connect the two cables from the interlock switch to slots 28 and 36 on the connector block. Remember to remove the link between slots 28 and 36 before connecting the cables from the interlock switch.

**WARNING:** Any of these connections should be performed by a qualified electrician or service engineer.

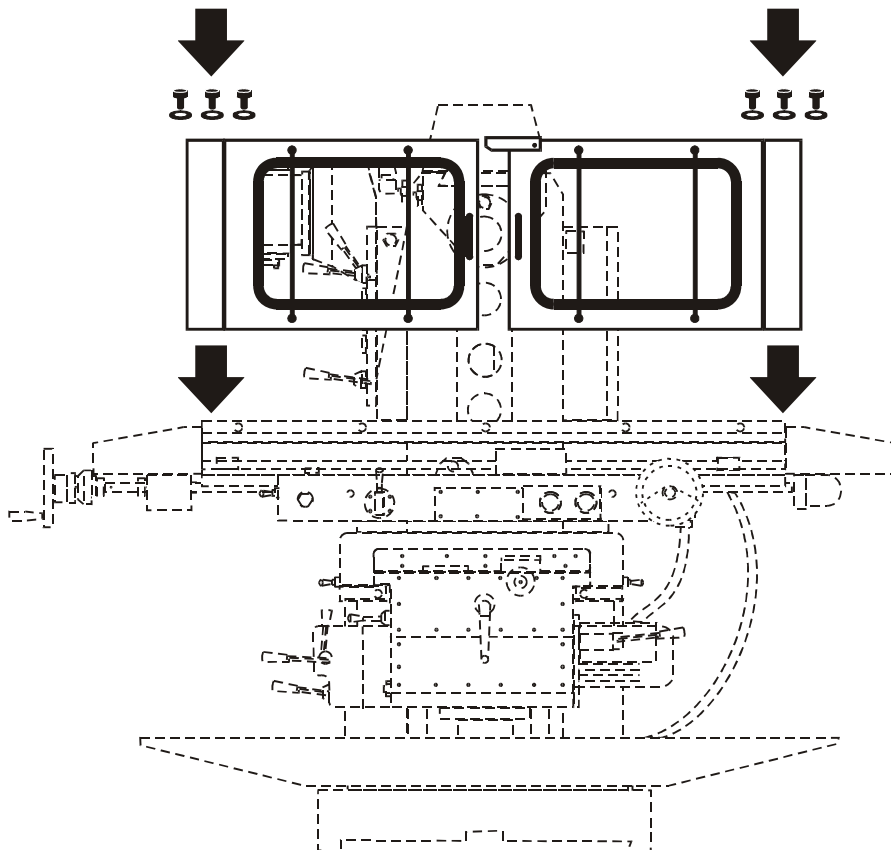

## PACKING LIST

Type: .....

Serial No:.....

*The accessories marked with "X" are included in the delivery*

No	Name	Designation	Q'ty	Delivered	Note
1	2	3	4	5	6
<b>1</b>	<b>ACCESSORIES MOUNTED ON THE MACHINE</b>				
1.1	Main electric motor No: ..... ..... kW ..... V ..... min <sup>-1</sup> ..... Hz	.....	1	<input type="checkbox"/>	
1.2	Feed electric motor No: ..... ..... kW ..... V ..... min <sup>-1</sup> ..... Hz	.....	1	<input type="checkbox"/>	
1.3	Frequence invertor ACSM1-04AS-09A5-4		1	<input type="checkbox"/>	
1.4	Encoder E40S8-2500-6-L-5		1	<input type="checkbox"/>	
1.5	Electric panel – complete: No ..... ..... V; ..... Hz		1	<input type="checkbox"/>	
1.6	Cooling system in a set with pump type ..... ..... Hz ..... V ..... min <sup>-1</sup>	3041.70.00.00	1	<input type="checkbox"/>	
1.7	Lubrication system with drive motor type ..... No: ..... ..... kW ..... V ..... min <sup>-1</sup> ..... Hz		1	<input type="checkbox"/>	
1.8	Lubrication unit with dosed feeding No: ..... ..... kW ..... V ..... min <sup>-1</sup> ..... Hz	.....	1	<input type="checkbox"/>	
1.9	Lighting for milling machines		1	<input type="checkbox"/>	
<b>2</b>	<b>STANDARD ACCESSORIES</b>				
2.1	Clamping rod – set	3041.91.00.00	1	<input type="checkbox"/>	
2.2	Handle for manual movement	3021.91.00.00	1	<input type="checkbox"/>	
2.3	Spanners				
	12 x 14		1	<input type="checkbox"/>	
	24 x 27		1	<input type="checkbox"/>	
	30 x 32		1	<input type="checkbox"/>	
	32 x 36		1	<input type="checkbox"/>	
	41 x 46		1	<input type="checkbox"/>	
2.4	Hexagon socket wrench				
	5		1	<input type="checkbox"/>	
	8		1	<input type="checkbox"/>	
	10		1	<input type="checkbox"/>	
	12		1	<input type="checkbox"/>	

1	2	3	4	5	6
2.5	Screw driver A1 260 x 7		1	<input type="checkbox"/>	
<b>3</b>	<b>ADDITIONAL ACCESSORIES</b>				
3.1	Horizontal swivel vice	.....	1	<input type="checkbox"/>	
3.2	Cutter arbor dia 22 - long	3041.92.00.00	1	<input type="checkbox"/>	a set
3.3	Cutter arbor dia 27 - long	3041.93.00.00	1	<input type="checkbox"/>	a set
3.4	Cutter arbor dia 32 - long	3041.94.00.00	1	<input type="checkbox"/>	a set
3.5	Cutter arbor dia 40 - long	3041.95.00.00	1	<input type="checkbox"/>	a set
3.6	Universal indexing device	UDA 160 Ser. No .....	1	<input type="checkbox"/>	Separate partlist
3.7	Rotary index table	KDM 320 Ser. No .....	1	<input type="checkbox"/>	Separate partlist
3.8	Slotting head	SG 321 Ser. No .....	1	<input type="checkbox"/>	Separate partlist
3.9	Vertical milling head	VFG 323 Ser. No .....	1	<input type="checkbox"/>	Separate partlist
3.10	Universal milling head	UFG 325 Ser. No .....	1	<input type="checkbox"/>	Separate partlist
3.11	Working area protection	3048.02.00.00	1	<input type="checkbox"/>	
3.12	Digital reading device	SIZO Ser. No .....	1	<input type="checkbox"/>	Separate partlist
3.13	Collet-chuck (set of collets and clamping tool)		1	<input type="checkbox"/>	
3.14	Clamping accessories - a set		1	<input type="checkbox"/>	
3.15	Automatic cycle for longitudinal traverse		1	<input type="checkbox"/>	
<b>4</b>	<b>SPARE PARTS</b>				
4.1	Rubber spider	3021.30.50.03	1	<input type="checkbox"/>	
<b>5</b>	<b>SPARE PARTS LIST</b>		1	<input type="checkbox"/>	

Date: .....

Packed by: .....

QC: .....

## TEST CERTIFICATE

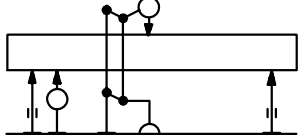
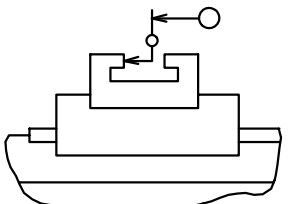
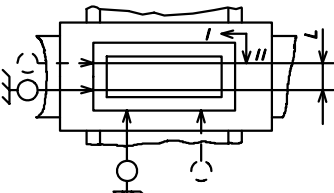
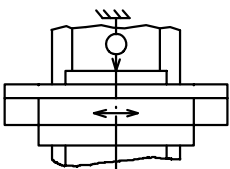
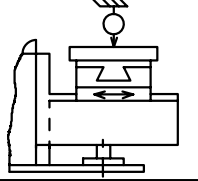
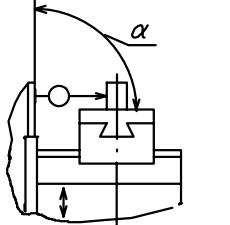
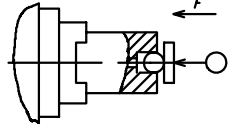
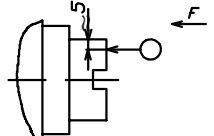
No	Inspection Item	Figure	Tolerance	
			Standard	Measured
1	2	3	4	5
1	2.1. Straightness on Table Top /concavity is allowed/		0.03 mm per 1000 mm	
2	2.2. Parallelism of the Table Longitudinal Movement to Table Reference T-Slot Side		0.03 mm per 1000 mm	
3	2.3. Squareness between Cross and Longitudinal Table Movement		0.02 mm per 300 mm	
4	2.4. Parallelism of the Longitudinal Table Movement to Table Top		0.03 mm per 1000 mm	
5	2.5. Parallelism of the Cross Table Movement to Table Top		0.025 mm per 300 mm	
6	2.6. Squareness between the Vertical Table Movement and the Table Top		0.025 mm per 300 mm $\alpha \leq 90^\circ$	
7	2.7. Spindle Axial Runout		0.010 mm	
8	2.8. Spindle nose Runout		0.018 mm	

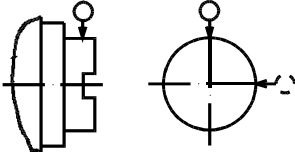
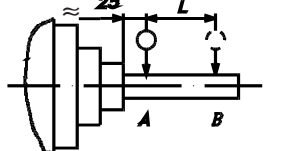
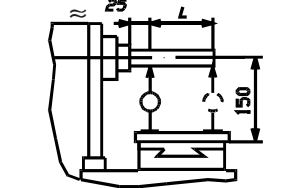
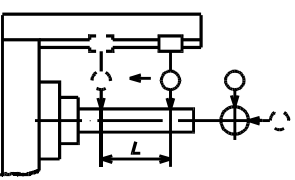
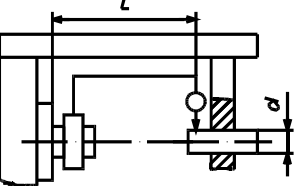
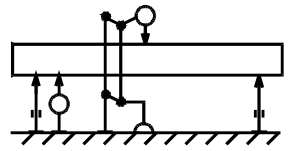
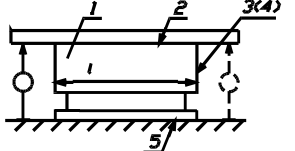
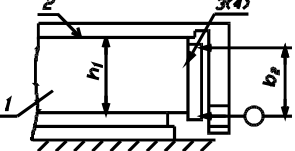

1	2	3	4	5
9	2.9. Radial runout of the spindle nose outer diameter		0.010 mm	
10	2.10. Radial runout of spindle female taper hole		0.010 mm to the Nose 0.02 mm per 300	
11	2.11. Parallelism of the horizontal spindle axis of rotation to the table top		0.025 mm per 300 mm	
12	2.12. Parallelism of yoke guideways to spindle axis of rotation in horizontal and vertical plane		0.02 mm per 300 mm	
13	2.13. Coaxiality of knee hole and horizontal spindle in vertical and horizontal plane		0.03 mm per 300 mm	
14	2.14. For machines with fixing element			
15	2.15. For vertical milling machines			
16	3.4. Straightnes of plane 1 and plane 2 (side and top)		0.025 mm per 300 mm	
17	3.5. Parallelism of sample workpiece planes in longitudinal and cross section		0.025 mm per 300 mm	
18	3.6. Squareness between sample workpiece plane 1 to planes 2 and 4 and between plane 2 to planes 3 and 4		0.020 mm per 100 mm	
Date: ..... QC: ..... QC Dept.Chief: .....				

## OPERATION

### DESCRIPTION OF MACHINE CONTROLS AND PARTS

/ Fig.3 and Fig.3a /

1. Index handle for vertical and cross table traverse
2. Saddle locking screw
3. Handwheel for longitudinal table travel
4. Handle for table longitudinal feed on/off
5. Limit switch for the longitudinal travel
6. Mechanism for yoke movement
7. Speed switch - over handle
8. Speed switch - over handle
9. Speed switch - over handle
10. Yoke tightening nut
11. Knee tightening nut
12. Table - to - saddle tightening screws
13. Longitudinal travel stop cams
14. Slide - to - knee tightening handle
15. Handle for cross feed on/off
16. Handle for longitudinal screw backlash elimination
17. Handle for vertical feed on/off
  
21. Handwheel for longitudinal table travel
22. Back cover
23. Cover
24. Vertical travel stop cams
25. Saddle locking screw
26. Knee - to - body tightening handle
27. Limit switch for the vertical travel
28. Cross travel stop cams
29. Limit switch for the cross travel
30. Safety clutch cover
  
41. Main breaker
42. Working light on/off switch
43. The operating mode selector
44. Coolant on/off switch
45. Emergency stop
46. Spindle start pulse button
47. Spindle on/off & direction of rotation switch
48. Rapid traverse button
49. Start button
50. Spindle stop button
51. Emergency stop
52. Signal lamp "Include tension"
53. Handle for feed reference potentiometer

## PREPARATION FOR START - UP

Before initial operation of the machine after unpacking, or keeping the machine idle for a long period, make a close examination and cleaning of all mechanisms, fill the tanks with oil / Fig.8a / and coolant and connect the machine to the mains as prescribed in the section "Electric Equipment".

The locking mechanism for the longitudinal travel 12, cross travel mechanism 14 and vertical travel mechanism 26 / Fig.3 / should be disengaged. All mechanisms should operate smoothly and trouble - free. Check that they do that by hand.

Check the proper functioning of the gear boxes by switching from lowest to highest gear speeds and feeds during idle running. At the same time constantly observe the lubrication system operation through the oil level indicators.

Warm up the machine by running it for 30 minutes at idle running mode.

Proir to initial use of machine, Emergency Stop functions should be checked. To check it start the spindle at max speed. After 10 seconds press one of the "Emergency Stop" buttons 45 or 51 / Fig.3a / and make a note of how long it tooks for spindle to stop. The function of each button should be checked separately.

Then start the machine in exactly the same way and after 10 seconds use the main breaker 41 / Fig. 3a / to stop the spindle. Measure the time for spindle stopping. It should take longer for spindle to stop when use the main breaker.

If the time of spindle stop is the same for both tests a qualified electrician should be called and the problem should be eliminated immediatly before the machine is used.

### CAUTION:

1. Remember: During a power failure the dynamic spindle stop will not be available.
2. When a vertical milling head, a slotting head or a universal milling head are used, the vertical stroke is limited. To prevent the danger of shock move the lower cam into the additionally machined screw hole to fix it.
3. The table swing towards the electric cabinet is limited in order to avoid the smash of the electric cabinet due to operator's carelessness. To swing the table to bigger angle remove the stopper placed to the outlet of support's T-slot and look out for not smaching the electric cabinet during table traverse on axis.

See and read carefully sections "Safety precautions" and "Maitenance".

## SELECTION OF SPINDLE ROTATION SPEED

Each one of 18 speeds is selected by relevant to the desired speed combination positioning of handles 1, 2 and 4 which are shown on the graphic panel scheme / Fig.9 /.

To facilitate the selection of desired speed, press the push - button 3 / Fig.9 / as you have the handle shifted from its fixed position and slight turning the handle. Do not change the spindle speed during machine operation.

## SELECTION OF FEED RATE

Choice of desired feed is achieved by handle for feed reference potentiometer 53 / Fig.3a /.

## SELECTION OF LONGITUDINAL FEED

The manual longitudinal feeds are effected by handwheels 3 and 21 / Fig.3 / and the automatic ones - by the handle 4 / Fig.3 /.

## SELECTION OF CROSS AND VERTICAL FEEDS

Manual feed in cross and vertical direction is accomplished by handle 1 / Fig.3 /. Remove the handle from the machine before putting on the automatic feed and the rapid traverse.

The automatic table feed in cross direction is realized by handle 15 and in vertical - by handle 17 / Fig.3 /.

## COOLING OF THE TOOLS

Turn the switch "Coolant On/Off" /Pos.44, Fig.3a / in position "ON".

## DRIVE UNITS ACTIVATING

The feed drive operation in cutting mode or at rapid traverse can be performed with or without spindle rotation. The direction of spindle rotation is chosen by "Spindle Off/Fwd/Rew" Switch 47 / Fig.3a /. Position "FWD" corresponds to the spindle rotation counter-clockwise, facing the spindle. "REW" means clockwise spindle rotation.

Main drive is activated by pressing of button "Start" / Pos.49, Fig.3a /, thus the circuits for feed motion and coolant pump are prepared for work.

The feed gear box electric motor is started by means of handles as follows:

- for longitudinal travel - handle 4 / Fig.3 /;
- for cross travel - handle 15 / Fig.3 /;
- for vertical travel - handle 17 / Fig.3 /.

**Attention:** It is forbidden to start the movement on axes if the guideways are clamped.

Rapid traverse movement is realised by pressing the "Rapid traverse" button 48 / Fig.3a /.

The movement of working table at immobile spindle is realized as follows: the "Spindle OFF/FWD/REW" switch / Pos. 47, Fig.3a / should be in OFF position; the operating mode selector 43 / Fig.3a / should be in position "Immobile spindle". The feed motions and the rapid traverse movement on the axes in the desired direction are performed as in the mode of spindle rotation.

The machine is stopped as one of the "Emergency Stop" buttons 45 or 51 /Fig.3a/ is pressed and it activates the electrodynamic stop of the spindle gear box.

The spindle stop is realized by pressing of button "Stop" button 50 /Fig.3a/.

When the handles for the travel direction are in zero position, the feed gear box electric motor stops.

The coolant system is activated and stopped by the "Coolant ON/OFF" switch 44 / Fig.3a / only when the spindle is rotating.

## DESCRIPTION OF THE MAIN MACHINE UNITS

The disposition of machine main units is shown in Fig.25.

### BODY, YOKE AND BRACKETS

The Body of the machine is a basic part where all units and mechanisms are assembled upon. The Body is fixed on a cast iron base which is used as a coolant tank as well.

The Spindle gear box electric motor is mounted in the back recess of the Body and the electric cabinet is fitted in the right recess of the machine Body.

The Yoke slides along the horizontal guideways. It is fixed on the Body by nuts 10 / Fig.3 /. The tightening force exerted on the spanner should be about 500-600 N. One or two brackets (depending on the type of work done) in which the bearings of the cutter arbors are positioned, are placed in the yoke front end. The bracket holes are machined on spot individually for each machine, so the brackets cannot be used on other milling machines. They are tightened to the Yoke by means of nuts 11 / Fig.3 /.

The radial backlash of bearing 7 / Fig.1, A-A / is adjusted by nut 8. The good functioning of the bearings 7 depends on the proper backlash adjustment and the sufficient lubrication. Non-observance of any of these conditions will cause seizure or premature wear out and breakage of the bearing 7.

### SPINDLE GEAR BOX

The gear box is mounted in the machine body and is driven by an electric motor through V-belts. The gear box ensures 18 spindle speeds / Fig.12 /.

The radial backlash of the spindle bearing is adjusted by the manufacturer and is within 0.004-0.005 mm. In case the bearing should be replaced by a new one, the radial backlash is adjusted with the help of nut 2 and ring 1 / Fig.4 /.

Belts 4 / Fig.10 / are tensioned as follows: open cover 22 / Fig.3 /, unscrew the nuts 3 / Fig.10 / and by bolts 2 / Fig.10 / the rocker 1 / Fig.10 / is inclined till tensioning of belts is performed. Then the bolts 2 are locked by nuts 3.

Belt tensioning is checked as it is pressed in the middle with force 100 to 150 N. The feed should be 20-25 mm.

**CAUTION:** Maximum allowed spindle torque should be 600 Nm.

## **SPINDLE GEAR BOX CHANGER**

It is a separate unit mounted on the left side of the body. It is shown in Fig.9.

## **FEED GEAR BOX**

It is mounted on the knee left side. The feed gear box is driven by an electric motor through a rubber spider.

## **KNEE**

All mechanisms realizing the machine feed motions are fitted to the knee / Fig.14 /.

The safety clutch (shaft VIII - Fig.14) disengages the feed motion in case of overloading. It is adjusted to transfer a torque of 140 Nm. In order to adjust the safety clutch by the nut 1 / Fig.6 / first you have to remove the cover 30 / Fig.3 / and then take the split pin 2 / Fig.6 / out.

The manual cross feed is switched off by cams 28 / Fig.3 / and microswitches 29 / Fig.3 / and the vertical - by cams 24 / Fig.3 / and microswitches 27 / Fig.3 /.

When the vertical travel is not used, the knee should be tightened to the body with the handles 26 / Fig.3 /.

## **SLIDE, SADDLE AND WORKING TABLE**

The slide is moving along the knee. It can be locked to the knee by means of handles 14 / Fig.3 /.

The saddle can swivel at 45 in both directions. It is locked by screws 2 and 25 / Fig.3 /.

A semi-automatic device for longitudinal screw backlash compensation is built - in the saddle. This backlash compensation is required only at climb milling and is done by handle 16 / Fig.3 /.

The working table is clamped to the saddle by the screws 12 / Fig.3 /.

## LUBRICATION

The lubrication circuit diagram is shown on Fig.8 and Fig.8a indicate the recommended lubricants for the various units.

The spindle gear box is lubricated by a reversible pump. The proper lubrication of the pump is checked through the oil level indicator 4. The oil is poured in the spindle gear box through plug 3 and is drained through pipe 1.

The feed gear box and the knee mechanisms are lubricated by a gear pump with motor 17. The oil in the knee is poured after removing cover 10 and is drained by loosening plug 14.

The lubrication of the guide ways for movement along the axes and the mechanisms placed in the saddle is performed by the centralized System for lubrication. The set lubrication time is for universal operation and is set by the manufacturer before the delivery of the machine. For special operations the time for lubrication is necessary to be changed (see "Operating and Maintenance Manual of System for lubrication").

Pour the oil after removal of the cup 8 and the level of the poured oil can be inspected on the transparent tank 9.

The oil for the vertical screw is supplied after removing cap 11. For this purpose the knee should be lifted to upper end position. The oil should be to the middle of the oil level indicator 16. It is drained through plug 15 as the knee should be in lower end position. The tank cleaning and the complete oil change is performed during machine repair.

When the vertical screw is in operation, it is necessary to move the knee once or twice per workshift in both end positions.

The bearing in the yoke brackets is lubricated by a wick - feed lubricator. The oil is poured through plug 5. The oil level should not be more than the middle of the oil level indicator 6.

During operation follow the instructions on the machine panels.



## COOLING SYSTEM

The cooling system consists of a coolant tank, a motor pump and a spout. The tank is situated in the base of the machine.

The quantity of the cooling liquid is about 50 l.

The base of the machine is provided with a tray whose purpose is to collect the coolant from the slides and the knee.

Coolant prolongs the life span of the cutting edges and improves the finish of the machine surfaces. Not only should these factors be taken into account on choosing a coolant type, but the damage it can do to the paintwork of the machine and rust it can cause to exposed metal surfaces as well. The motor pump situated at the back part of the column is started by a switch "Coolant ON/OFF" / Pos.44, Fig.3a / on the control panel.

The coolant driven by the motor pump is pumped to the spout at the front part of the column. The spout can be adjusted to any position and remains in this position with required angle.

The spout has a cylindrical part with a double function - shut-off cock and setting of the coolant flow by means of turning the tap. Even if the motor pump is ON there is no problem in having the tap closed

### Recommended Coolants

Mobil - Mobilcut 262

If coolants are used from another firm it is recommended COSHH sheets.

**Warning:** When working with materials that may be flammable such as Aluminium etc. use high flash point coolant.

## MAINTENANCE

### SAFETY PRECAUTIONS

Complying with the following advice may reduce the possibilities of an accident when carrying out maintenance. However, depending on where the machine is installed and the type of work (amongst other factors), additional safety measures might be necessary.

- \* Maintenance should be carried out by qualified staff. Each person should only carry out the area of maintenance which has been assigned to him/her.
- \* Maintenance staff should follow the instructions given by the manufacturer, or in the case of replacing a machine component, the instructions of the manufacturer or dealer of that component.

**IMPORTANT:** if in doubt, consult the manufacturer.

- \* Do not smudge or tear off the safety stickers provided by the manufacturer.
- \* It is important to provide safety gear, appropriate tools, adequate lighting, material and spare parts with the same or equivalent specifications as the original ones, warning signs, etc. when carrying out maintenance or repairs.
- \* Study the problem in case of machine break down. If the cause has been detected, work out a workplan (staff, estimated work time, material and spare parts, technical information, etc.). In any other case, do not touch anything, but consult the manufacturer or the machine dealer.
- \* Keep a logbook with all information related to maintenance and repairs. All maintenance staff should have access to this information.

A good periodical and preventive maintenance schedule can guarantee efficient machine performance for many years.

### DAILY MAINTENANCE

- \* Clean swarf, dust and dirt from work table and bed.
- \* Drain oil and fluids from the table.
- \* Clean all sliding surfaces.
- \* Clean the visible spindle surfaces.

\* Carefully clean all electrical surfaces with the machine disconnected from the mains.

\* Check oil and grease level. Fill if necessary. The regularity of the units greasing is shown in Fig.8a.

\* Check for oil leaks.

\* Check that all tubes are well connected and do not present leaks. If any fault has been detected, take the necessary steps.

\* Overall cleaning of the windows of the workspace's safety-guard and their exchange, if necessary.

### **WEEKLY MAINTENANCE**

\* Continue with the daily maintenance.

\* Clean the spindle nose and check for cracks or other visible damage and that the work holding can be performed smoothly.

### **MONTHLY MAINTENANCE**

\* Continue with the weekly maintenance.

\* Clean the electrical control.

\* Check the machine levelling and that the anchoring bolts are tightly bolted down.

\* Set all slide gib strips if necessary.

\* Check the terminals of the electrical connections to see if they have loosened or become disconnected.

\* Drain the coolant and change it every two months.

### **HALF-YEARLY MAINTENANCE**

\* Continue with the monthly maintenance.

\* Clean the electrical control and the machine.

\* Clean the greasing and coolant tanks, and change oil, coolant and filters if necessary.

\* Check the bearings making a noise and change them if necessary.

## LIST OF BEARINGS

n°	DESIGNAZIONE		DIMENSIONI	n° per macchina
	GOST	SKF / FAG		
Spindel gear box / Fig.13 /				
1	208	6208	40 x 80 x 18	2
2	405	6405	25 x 80 x 21	1
3	307	6307	35 x 80 x 21	2
4	308	6308	40 x 90 x 23	3
5	8124 A	51124 P6	120 x 155 x 25	2
6		NN 3022 KSP	110 x 170 x 45	1
7		N 214 P 5	70 x 125 x 24	1
Feed gear box / Fig.15 /				
1	1303	2303	17 x 47 x 14	1
2	105	6005	25 x 47 x 2	2
3	306	6306	30 x 72 x 19	2
4	205	6205	25 x 52 x 15	1
5	8209	51209	45 x 78 x 20	1
6	206	6206	30 x 62 x 16	3
7	7305	30305	25 x 62 x 18,5	1
8	7205	30205	25 x 52 x 15	2
9	7000103	16003	17 x 35 x 8	2
10	3306	51306	30 x 60 x 21	2
11	60207	6207	35 x 72 x 17	1
12	8112	51112	60 x 85 x 17	2
13	111	6011	55 x 90 x 18	4
14	941 / 25		25 x 32 x 16	2
15	942 / 30		30 x 38 x 24	2
16	80206	6206.2Z	30 x 62 x 16	1
17	8106	51106	30 x 47 x 11	1
18	943 / 25		25 x 32 x 25	1
19	80204	6204.2Z	20 x 47 x 14	1
20	2007108	32008X	40 x 68 x 19	2
21	7306	30306	30 x 72 x 24	5
22	6870 - 54		Needle roll 3 x 24	124
23	7207	30207	35 x 72 x 18,5	1
24	207	6207	35 x 72 x 17	2

## ELECTRIC EQUIPMENT

The electric power supply of the machine is realized through a 3 phase power supply line with a voltage and frequency being specified in the "Packing list or on the data plate, placed of the electric box door.

The electrical equipment secures a normal operation of the machine with input power supply fluctuations of  $\pm 10\%$  and frequency fluctuations of  $\pm 2\%$  of the rated values.

The electrical power supply is realized by power cable  $4 \times 6 \text{ mm}^2$  when four-wire mains is used and  $5 \times 6 \text{ mm}^2$  in case of five-wire mains. The cable passes through the electric inlet, placed on the electric box. It is connected to main breaker's Q1 terminals L1, L2, L3 and, depending on the mains type, to the terminal PE or N, situated close to the main breaker Q1.

After the connection check whether the movements directions of machine correspond to those set by means of the control levers and change the phase sequence on two of terminals L1, L2 or L3 when it is necessary.

The degree of protection of the machine is IP44 according EN 60529.

The electric circuit diagram and the wiring diagram are presented on Fig.16 and Fig.17.

## ELECTRIC EQUIPMENT

Nr.	DESIGNATION	Q'ty	NAME	TYPE	PRODUCER
1	Q1	1	Power circuit main breaker	OT45E3	ABB
2	Q2	1	Automatic breaker	MS116 - 16	ABB
3	Q3	1	Automatic breaker	MS116 - 16	ABB
4	Q5	1	Automatic breaker	MS116 - 0,25	ABB
5	Q6	1	Automatic breaker	MS116 - 0,63	ABB
6	Q7	1	Automatic breaker	MS116 - 0,25	ABB
7	M1	1	Spindle motor	T132 M – 4 B3 50 Hz – 7.5 kW 1445 min <sup>-1</sup>	ELMA-Bulgaria
8	A30M1	1	Feed motor	T 100 LA – 4 B5 50 Hz – 2.2 kW 1410 min <sup>-1</sup>	ELMA – Bulgaria
9	M4	1	Coolant pump	SAP PA – 35 50 Hz – 0.09 kW 2800 min <sup>-1</sup>	Porcia –Italia
10	T1	1	Transformer	50/60 Hz 220 – 440 V/ 20, 40, 24, 18, 29, 12 V	Bulgaria
11	F1	1	Automatic breaker	S202-K 4	ABB
12	F2	1	Automatic breaker	S201-C 20	ABB
13	F3	1	Automatic breaker	S201-C 3	ABB
14	F4	1	Automatic breaker	S201-C 2	ABB
15	F6	1	Automatic breaker	S201-C 2	ABB
16	G1, G2	2	Solid rectifier	KBPC 50A/100V	
17	H	1	Lamp	12V 20W	
18	A0A1	1	Resistor, condenser, diode		
19	K1, K2, K3	3	Relay	CR-M024DC4	ABB
20	KM1, KM2, KM3, KM7, KM8	5	Contactora	A 16-30-10/01/	ABB
21	KM6, KM10, KM11	3	Contactora	A 09-30-10	ABB
22	K20, K23, K24, K25	4	Contactora	K6-31Z	ABB
23	A2S1, A1S1	2	Emergency stop	MPMT3-10R/CE4T-10R-01	ABB
24	A1S5	1	Pushbutton	MP1-20R	ABB
25	A2S2, A1S7	2	Pushbutton	MP1-20B	ABB
26	A1S6	1	Pushbutton	MP1-20W	ABB
27	A1S8, A1S4	2	Selector switch 3-position	M3SS1-20B	ABB
28	A1S2, A1S3	2	Selector switch 2-position	M2SS2-20B/ C2SS2-30B	ABB
29	A3S1, A3S2, A3S3, A4S1, A4S2, A4S3, A5S1, A5S2, A5S3, A5S4, A6S1, A6S2, A6S3	13	Switch	S800E	ISKRA
30	A4S4, A4S5, A5S5, A5S6, A6S4, A6S5	6	Microswitch	BSE 30.0	Balluff – Germania
31	R1	1	Potentiometer	SZ1RV1202	Telemecanique
32	A0A28	1	Frequency inverter	ACSM1-04AS-09A5-4	ABB
33	KT1, KT2	2	Electronic time relay	CT-ERE /0.1-10s/	ABB
34	A1H1	1	Pilot light – LED	CL-502G	ABB
35	A1S10	1	Unblocking box	EL1-B134	ELMARK
36	A27	1	Encoder	E40S8-2500-6-L-5 / 8.5000.B14B.2500.0060	Autonics / Fritz Kubler GmbH

# COMPONENTS LAYOUT

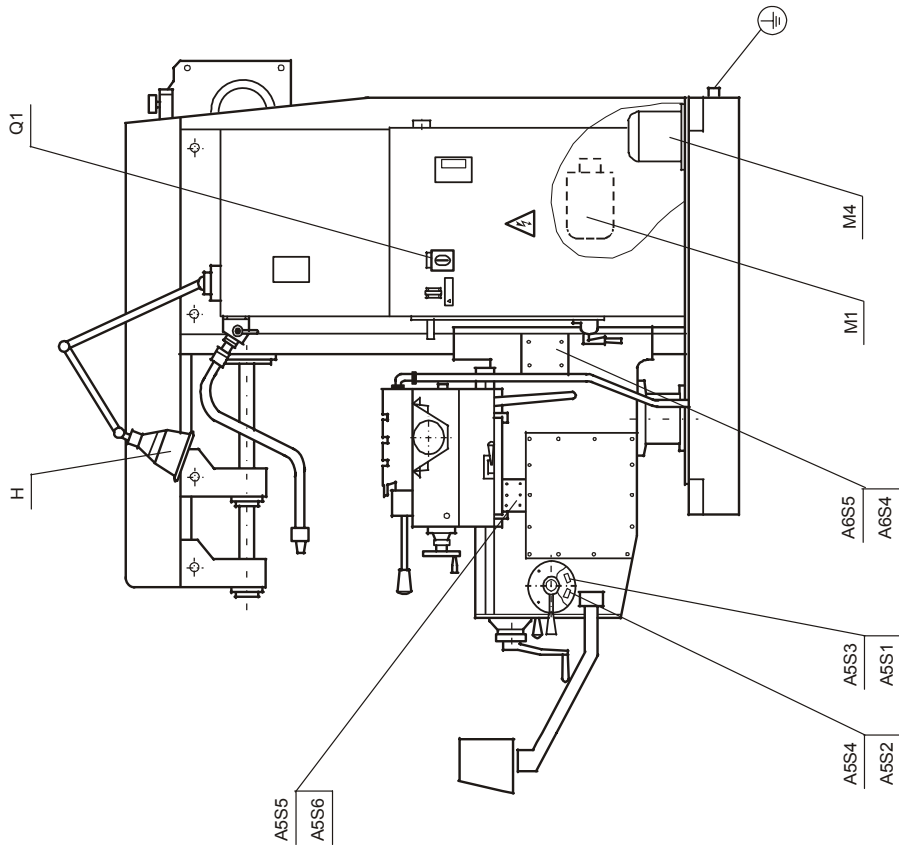
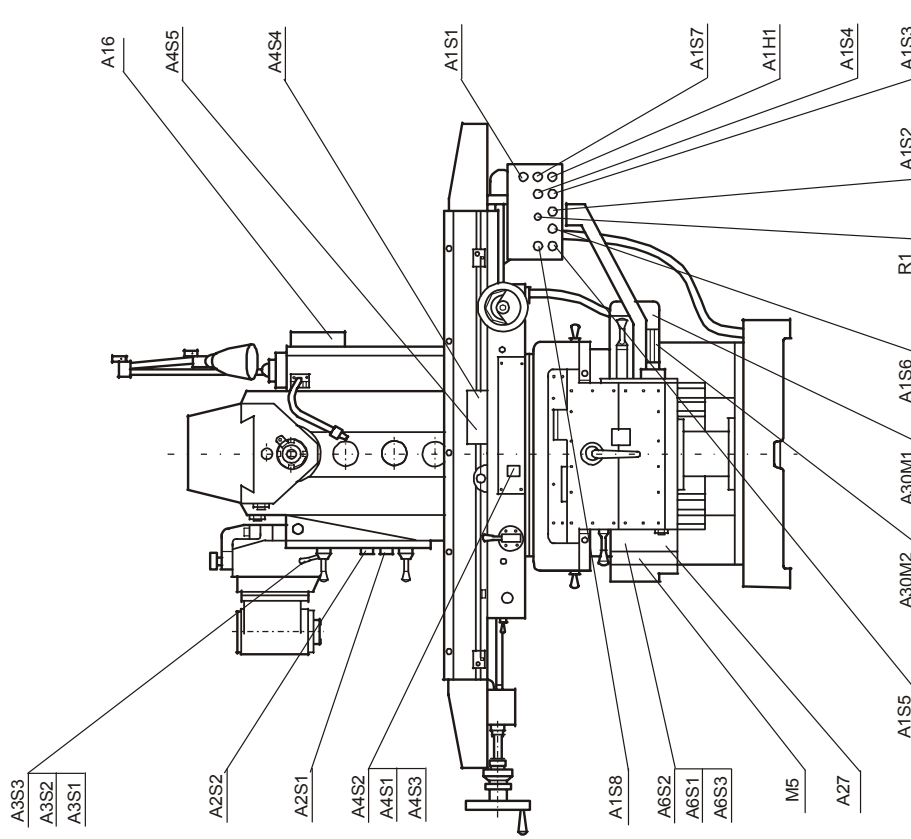

# ELECTRIC EQUIPMENT DETAILS

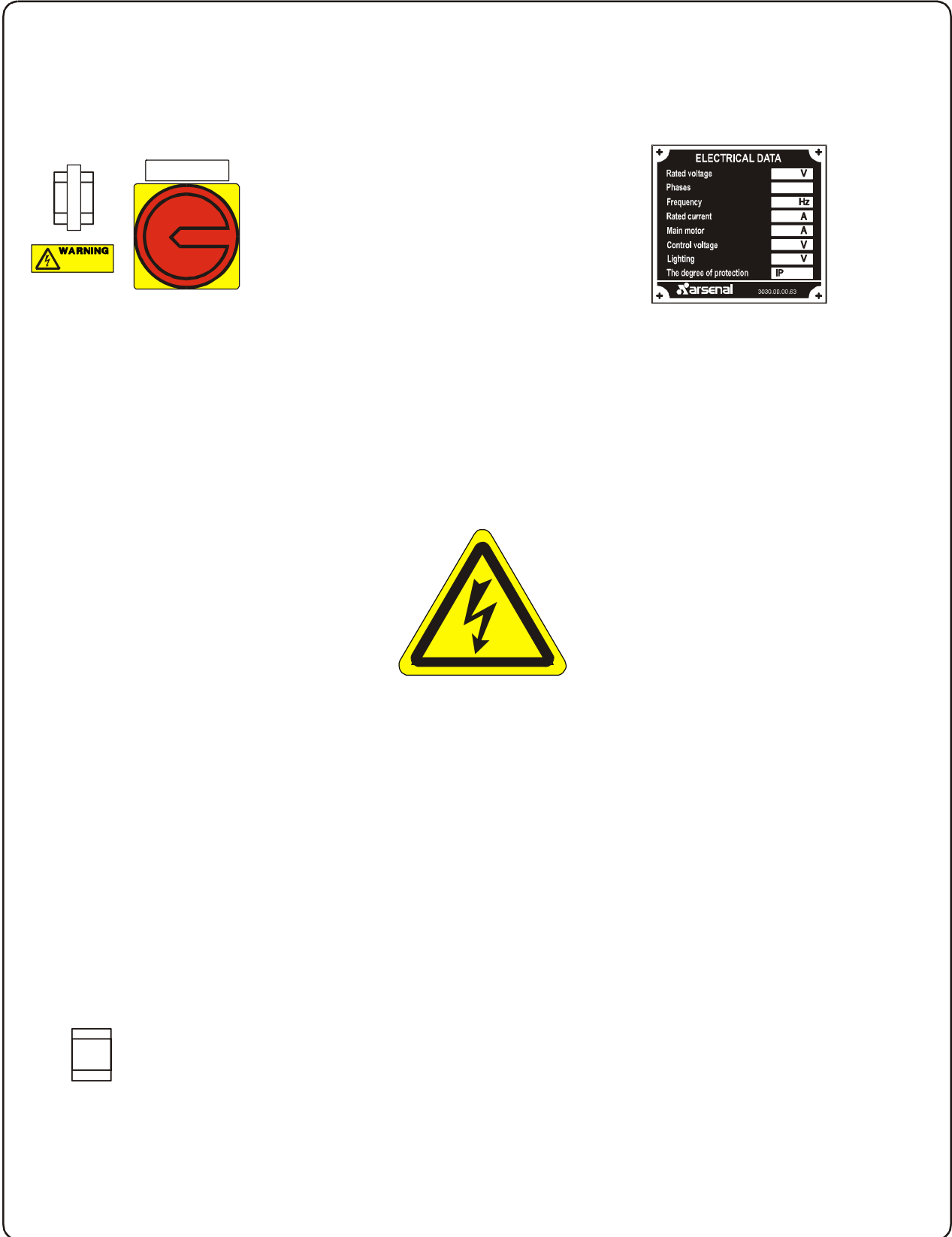



# ELECTRIC ARRANGEMENT

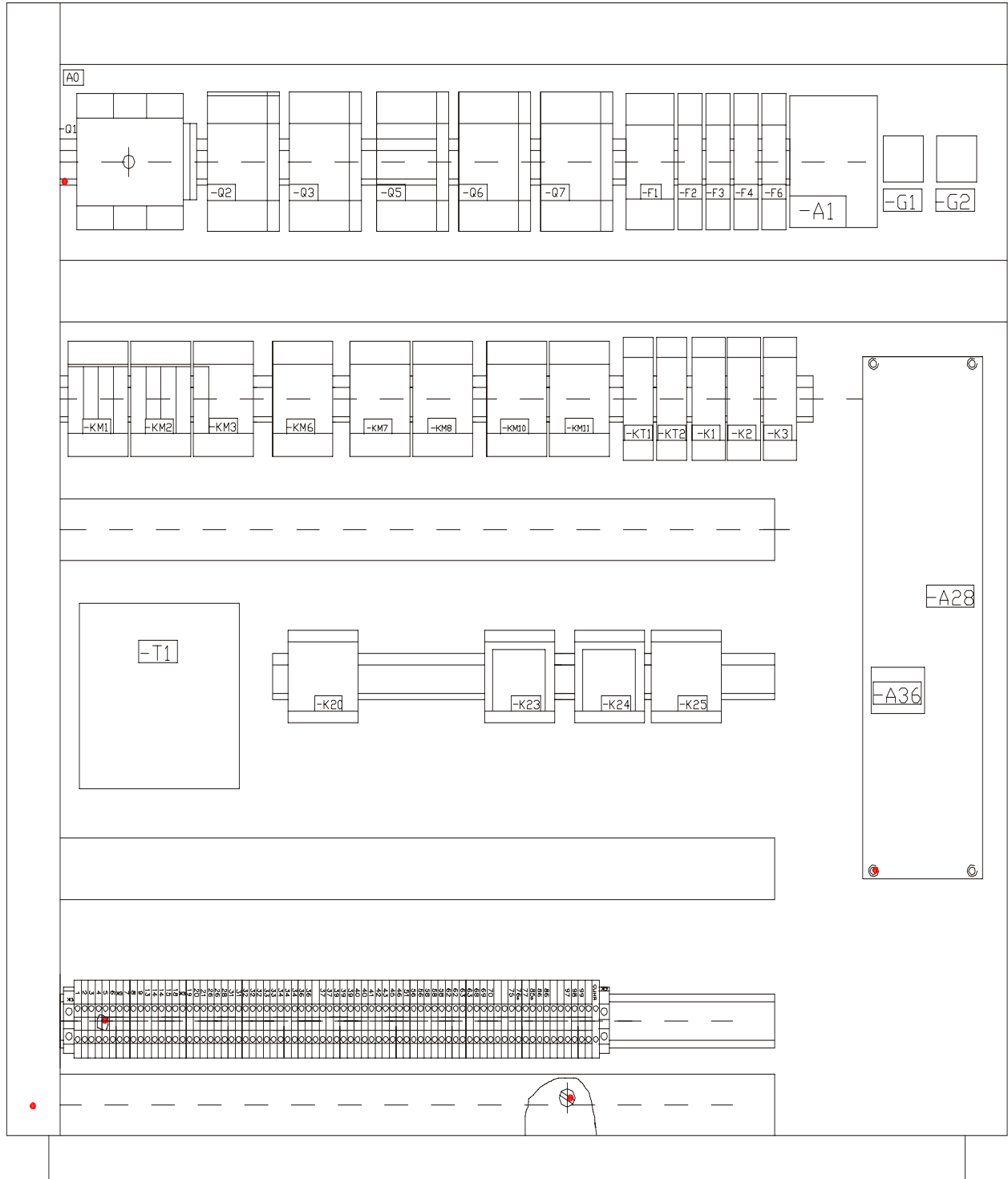

### BUTTON ARRANGEMENT FRONT PANEL

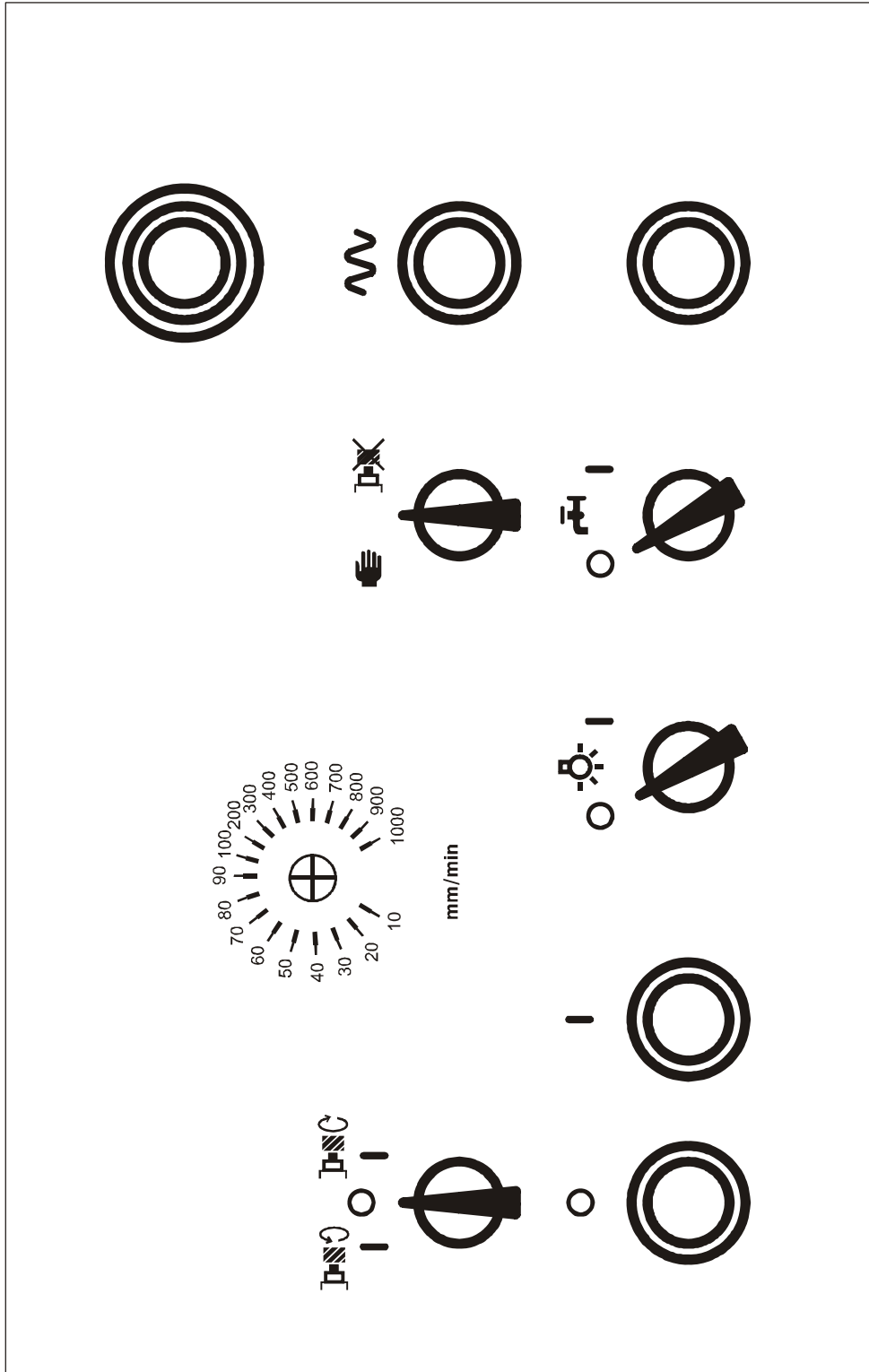

# BUTTON ARRANGEMENT SIDE PANEL

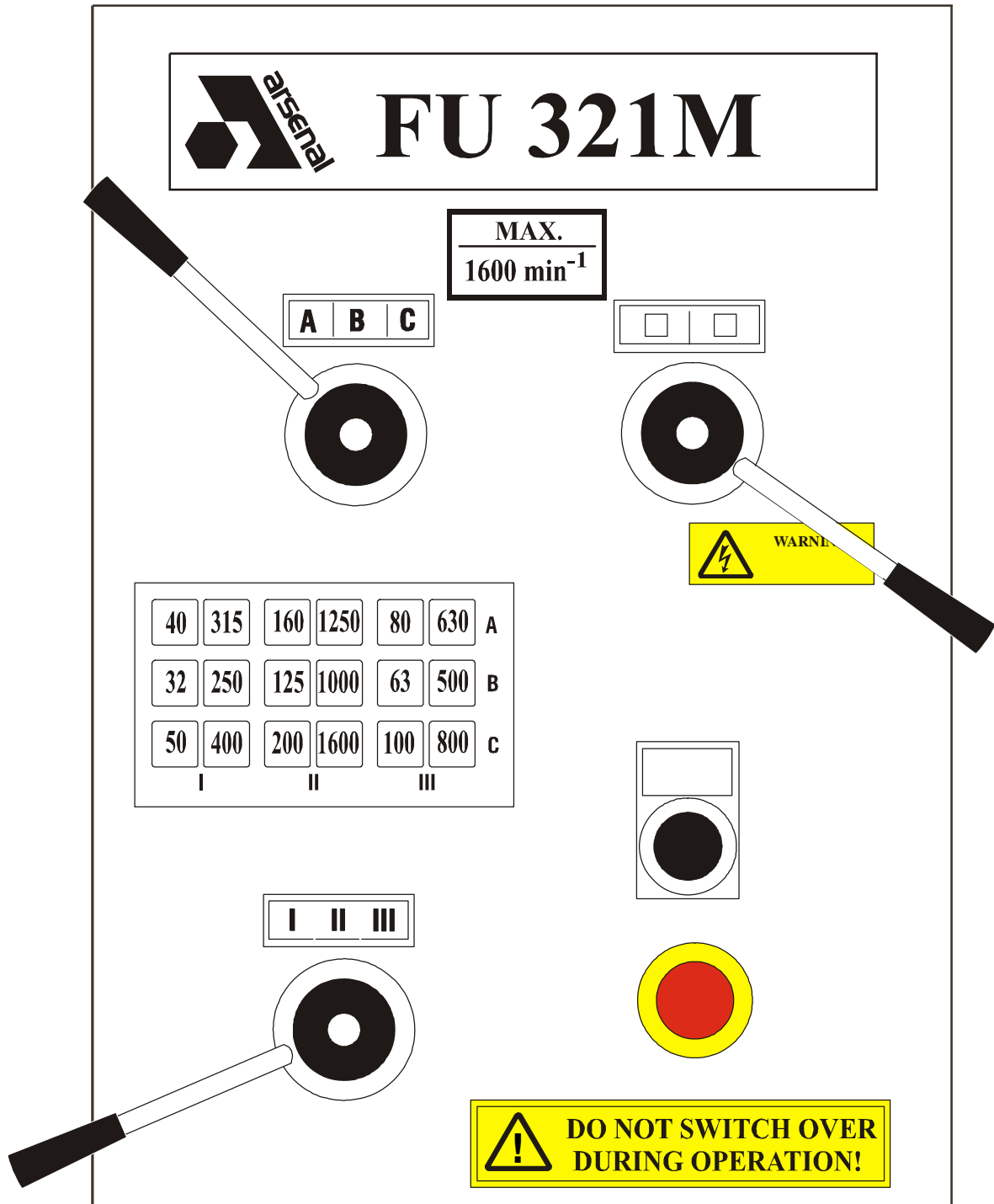

# DRAWINGS AND CHARTS

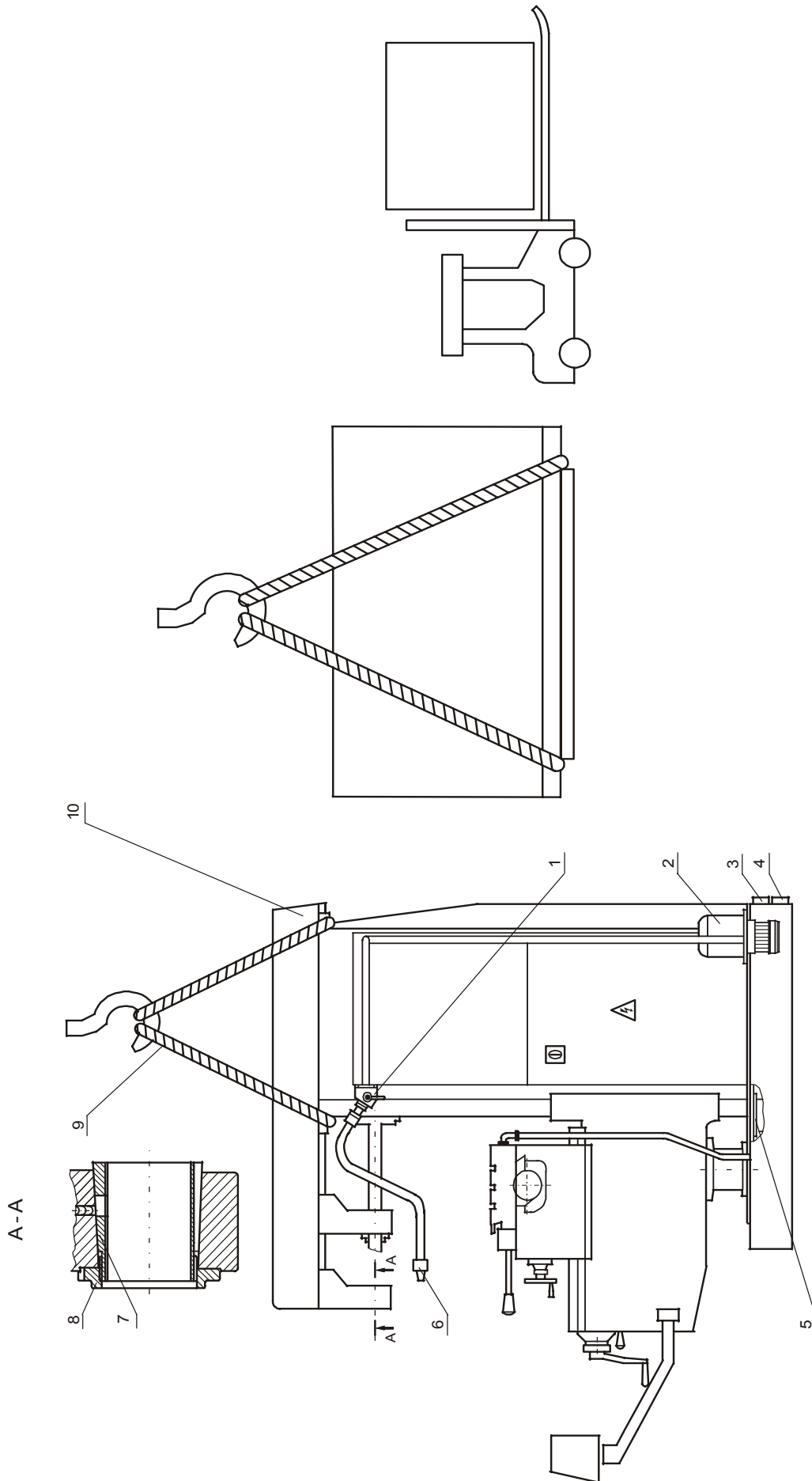

Fig. 1

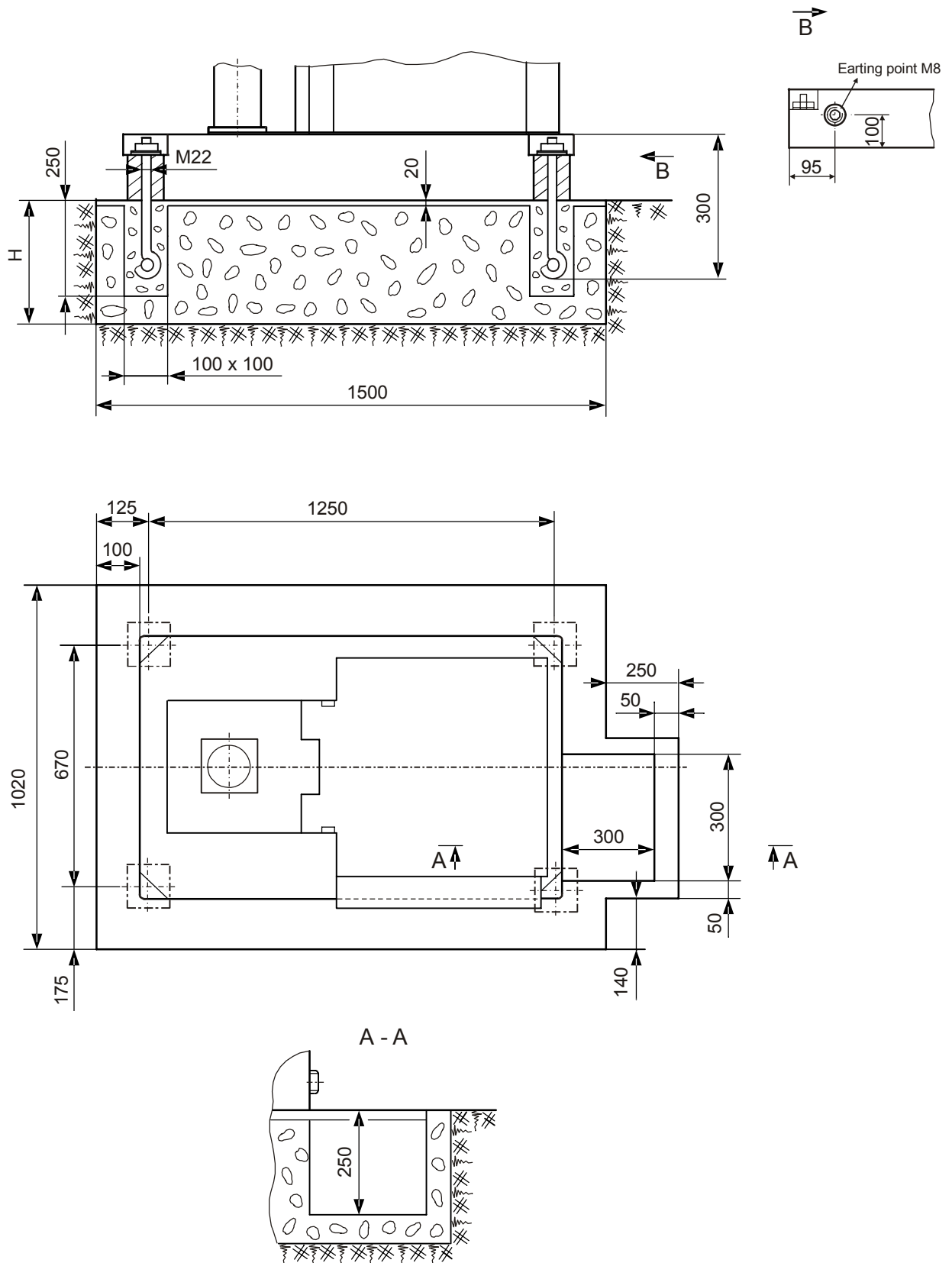

Fig. 2

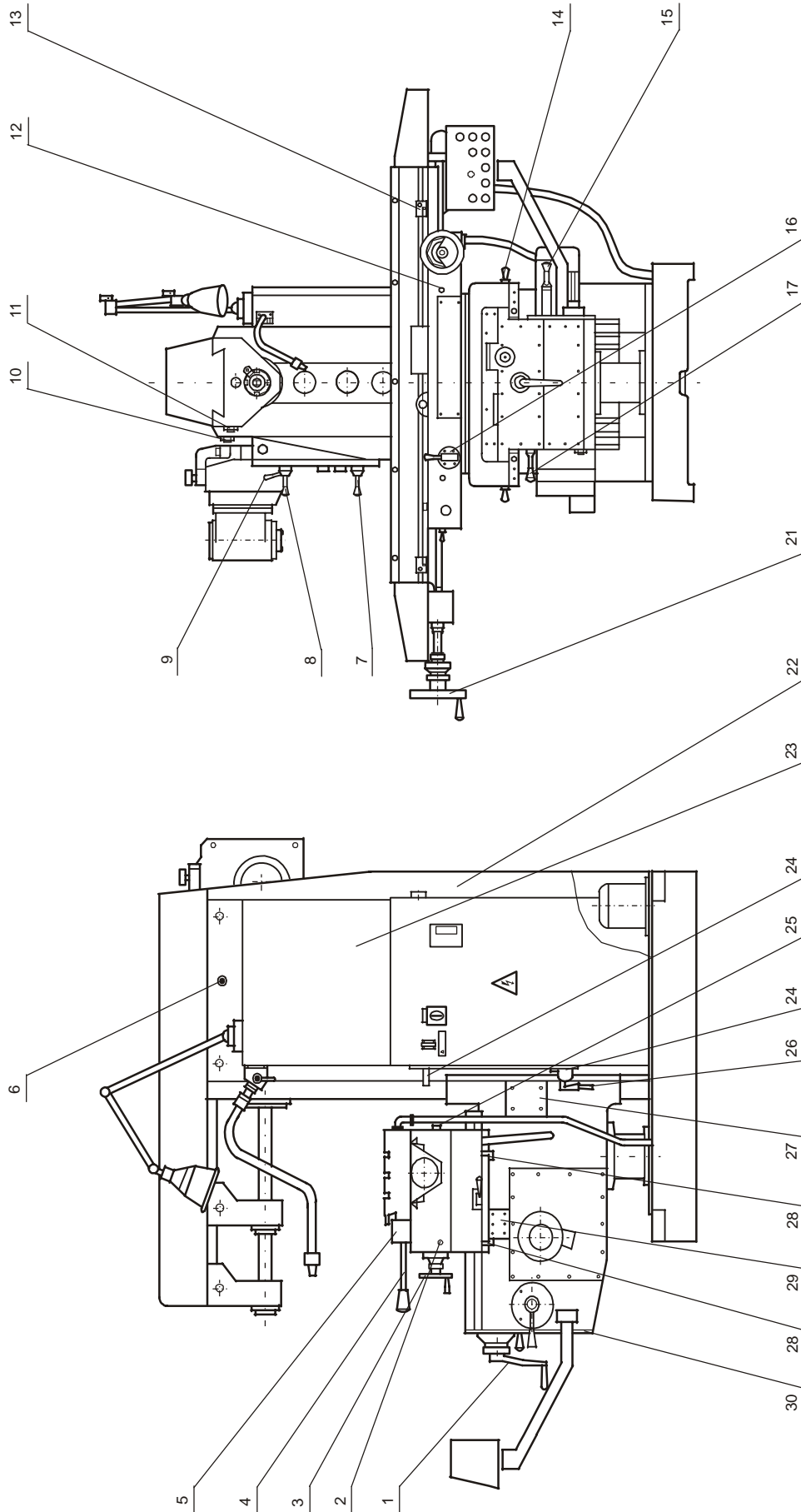

Fig. 3

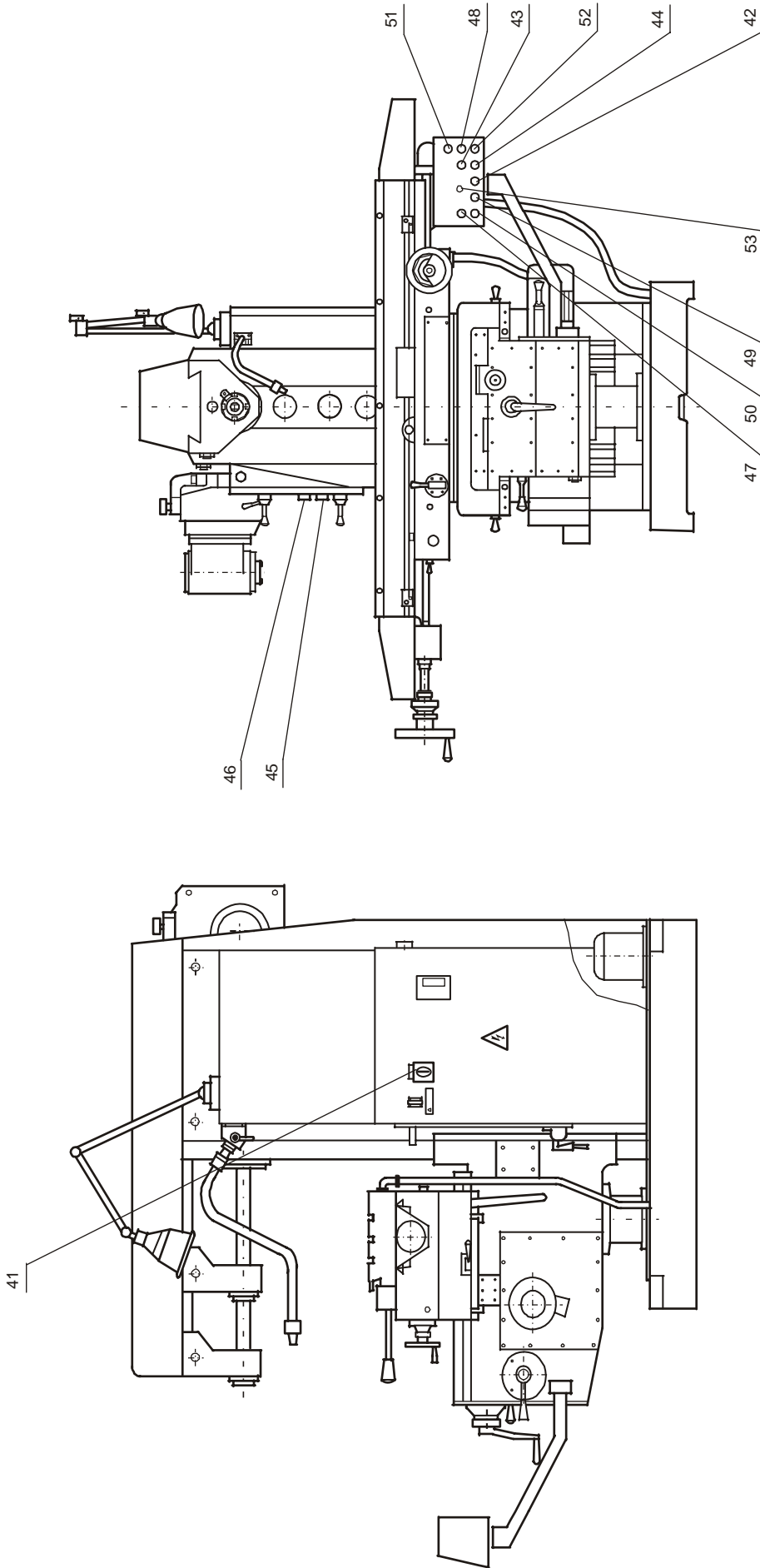
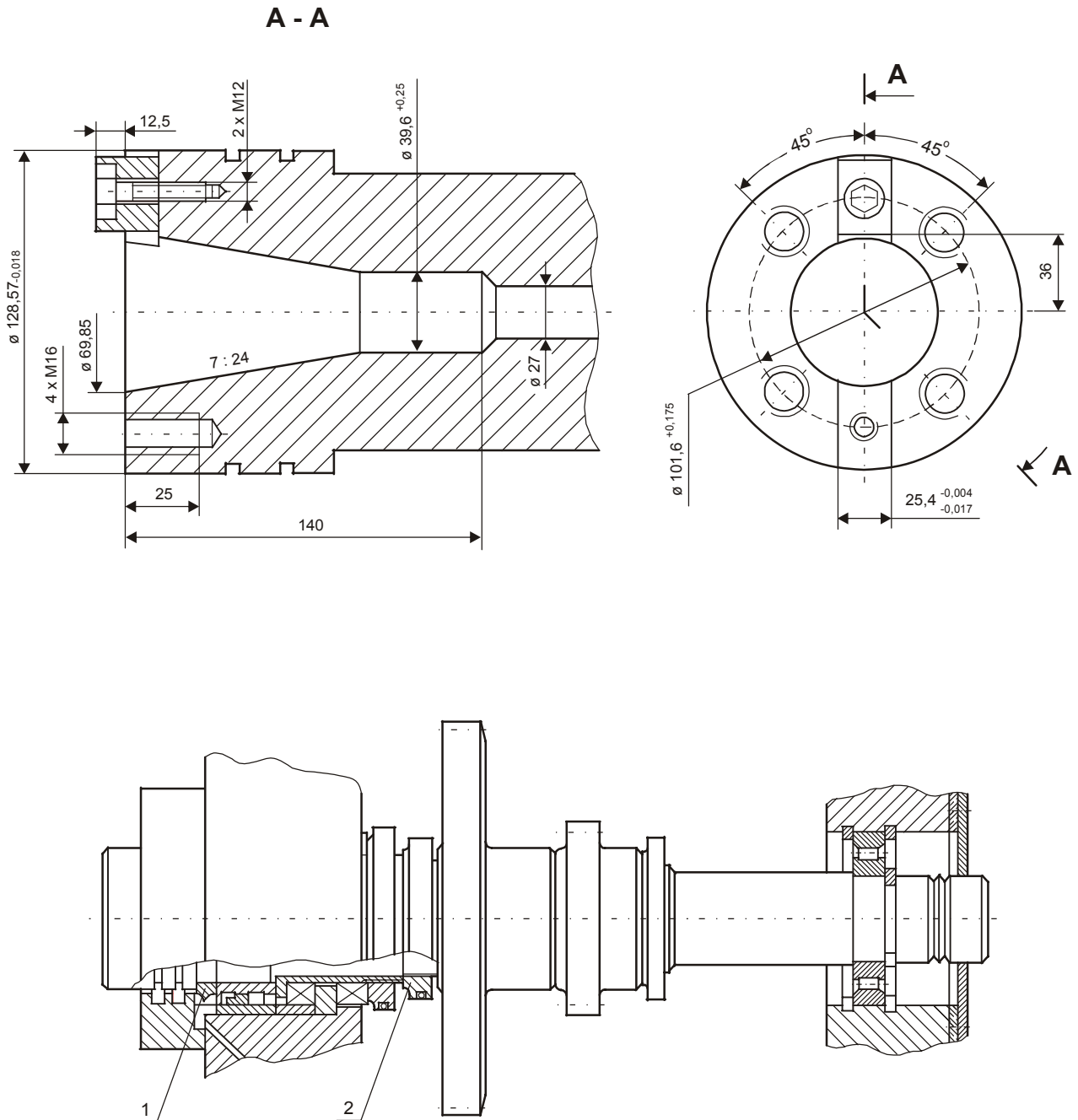

Fig. 3a

## SEMI-AUTOMATIC CYCLE





**Fig. 4**

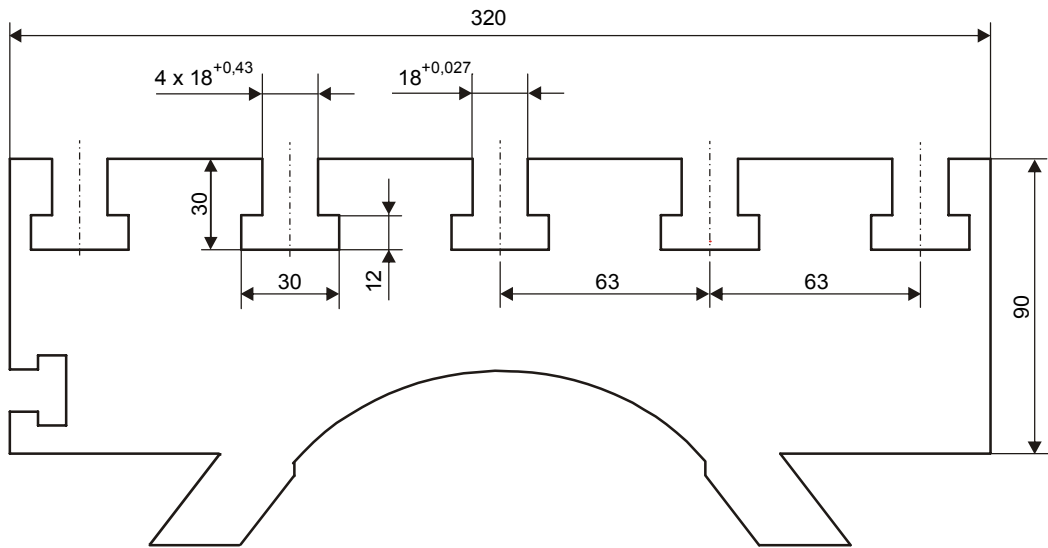
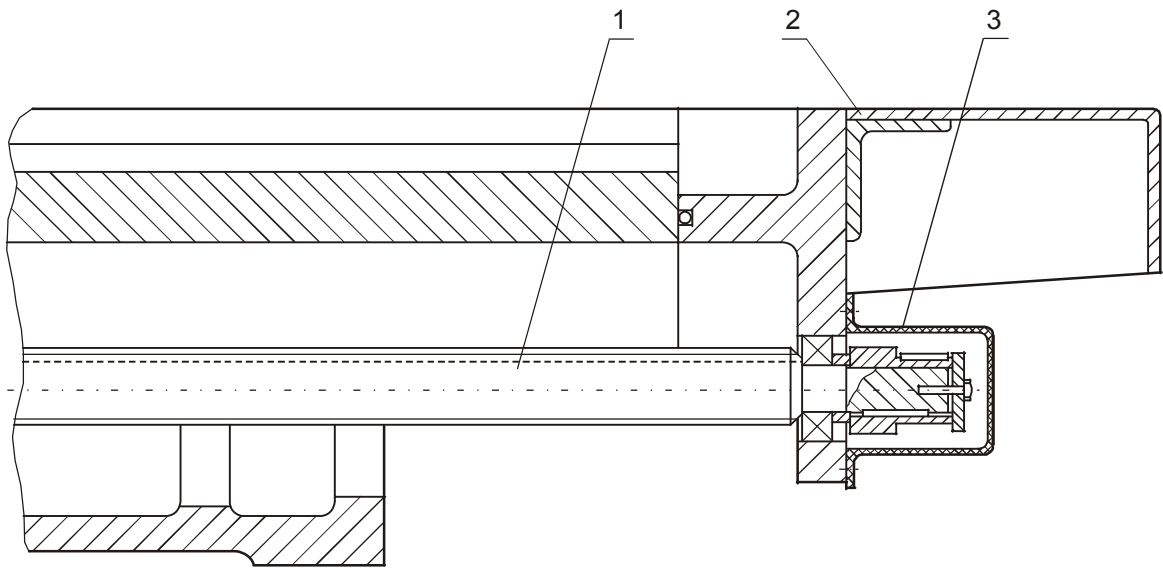
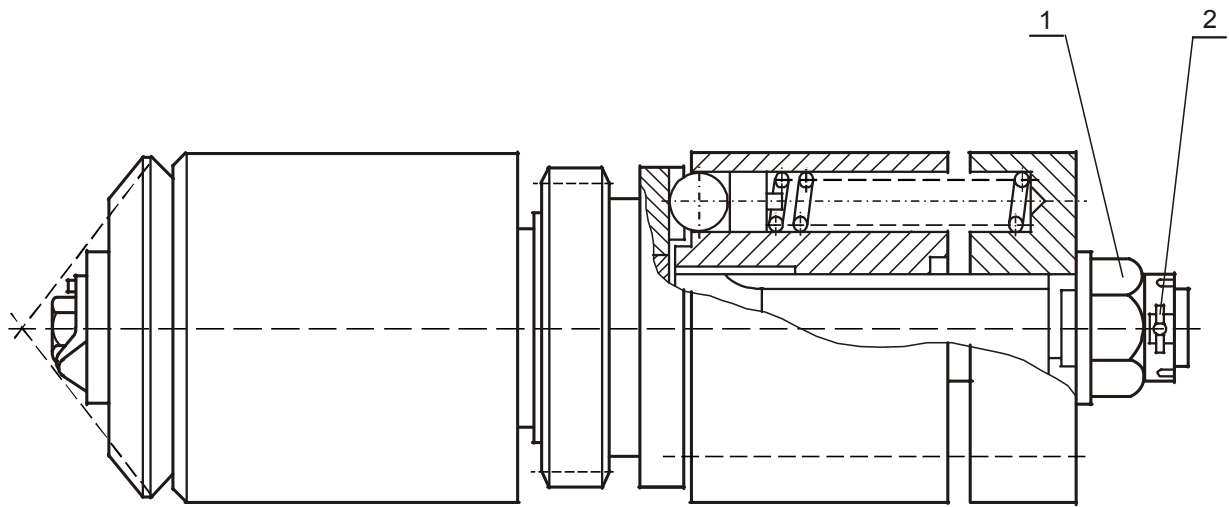

Fig. 5



**Fig. 6**

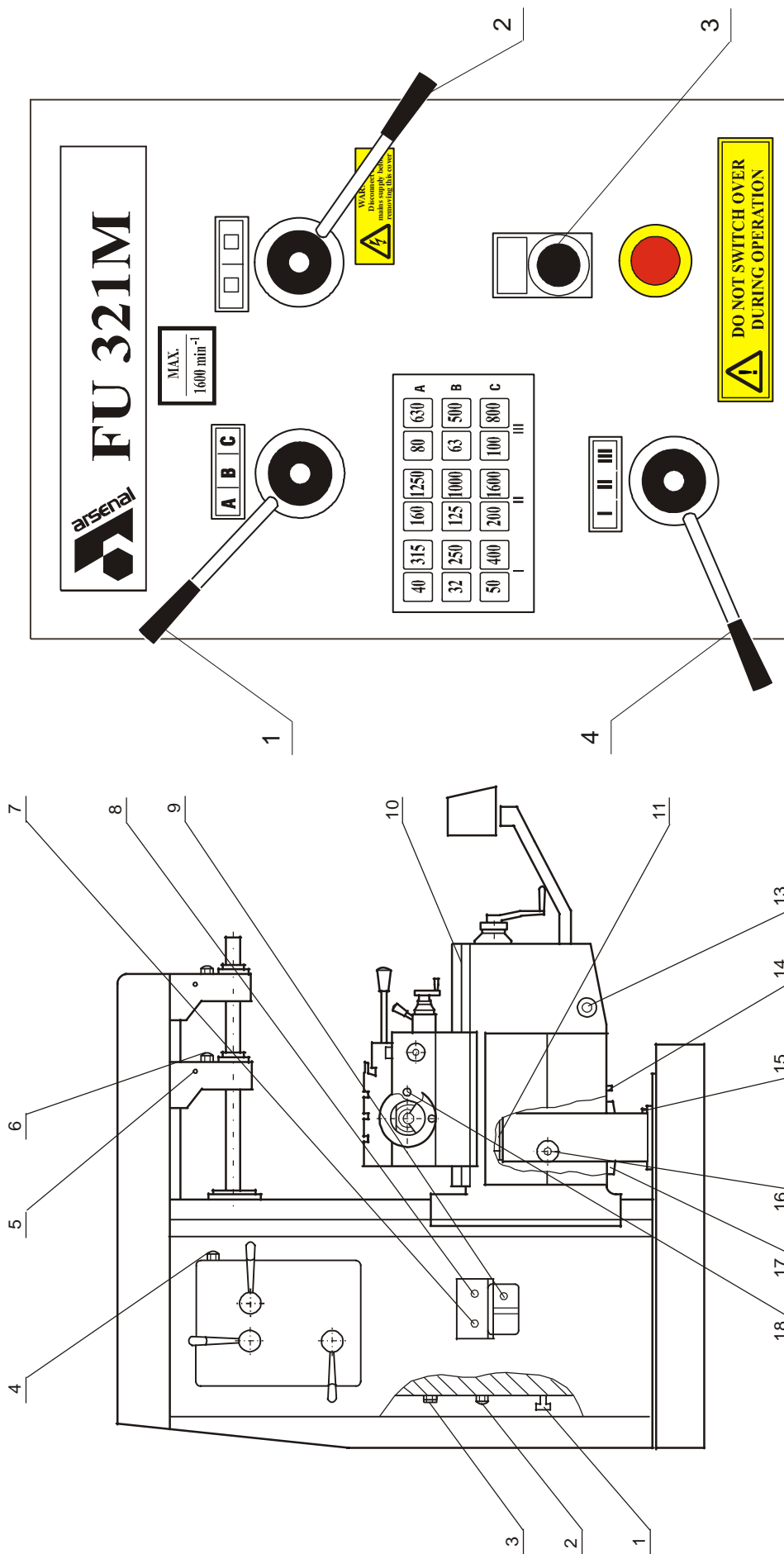

Fig. 9

Fig. 8

## LUBRICATION AND GREASING OF MACHINE

	OIL			GREASE
	Group I	Group II	Group III	Group IV
MOBIL	Mobil Vactra Oil No 2	Mobil Vactra Oil No 4	Mobil Gear Oil 600XP 320	Mobilith SHC 220
Quantity per machine	$\approx 19 \cdot 10^{-3} \text{ m}^3$	$\approx 3 \cdot 10^{-3} \text{ m}^3$	$\approx 0,75 \cdot 10^{-3} \text{ m}^3$	0,05 kg

- SYMBOLS:**
- Oil daily
  - Oil weekly
  - △ Oil monthly
  - △ Check level every week
  - Quantity

The first change of oil in the spindle gear box and in the knee is performed after 300 operating hours, the second - after 500, the third - after 1500 and then after each 4000 operating hours. It is recommended to wash the spindle gear box and the knee with pure oil prior to filling. The oil must be to the middle of the oil level indicators 2 and 13 / Fig.8 /.

If this task do not carried out the performance of the machine will suffer and the long run may cause breakdown. If lubricants are used from another firms it is recommended COSHH sheets.

**Attention:** Do not start the machine before filling with oil.

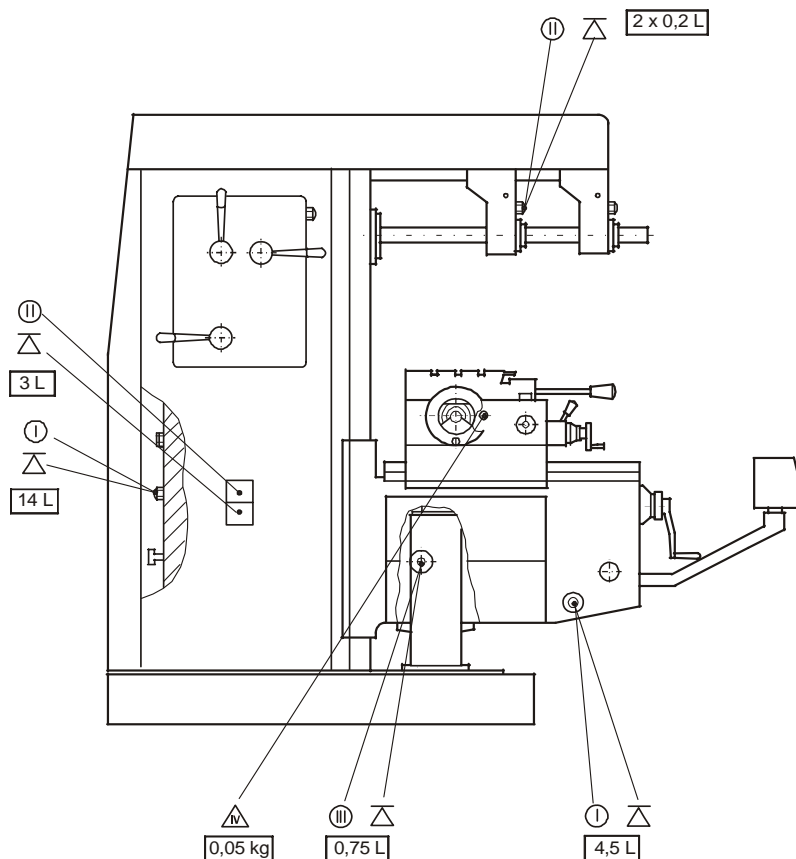

**Fig. 8a**

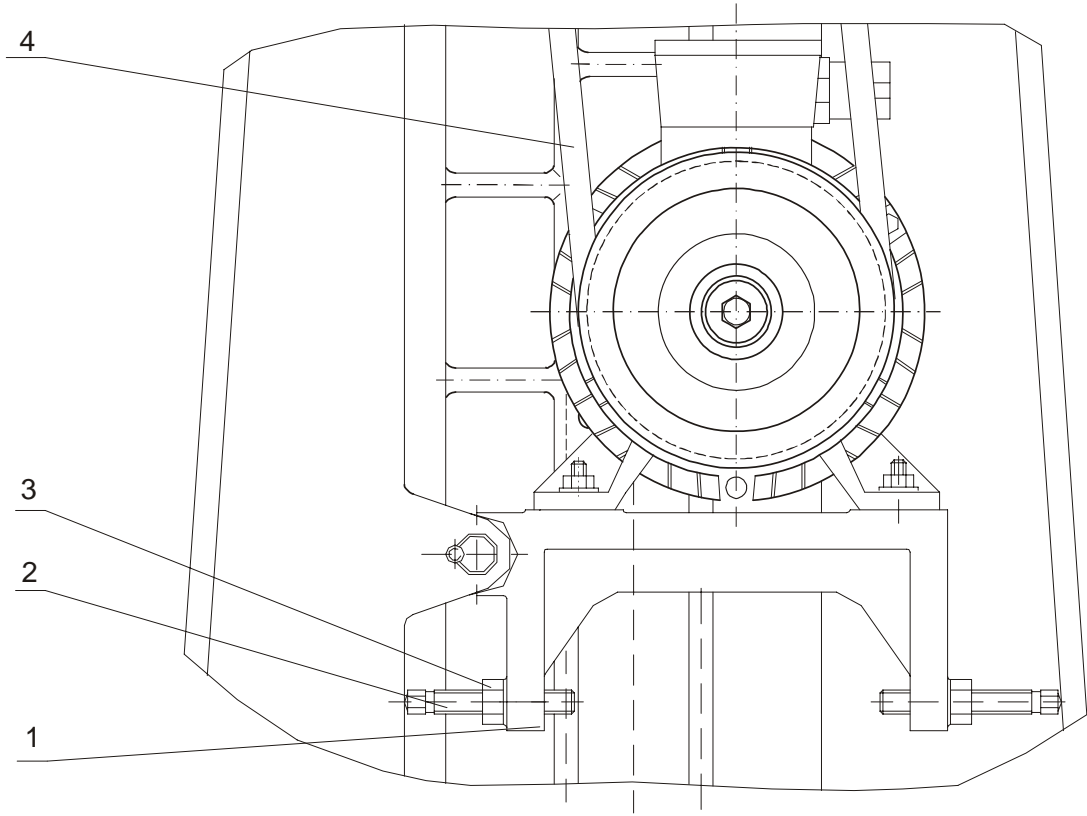

**Fig. 10**

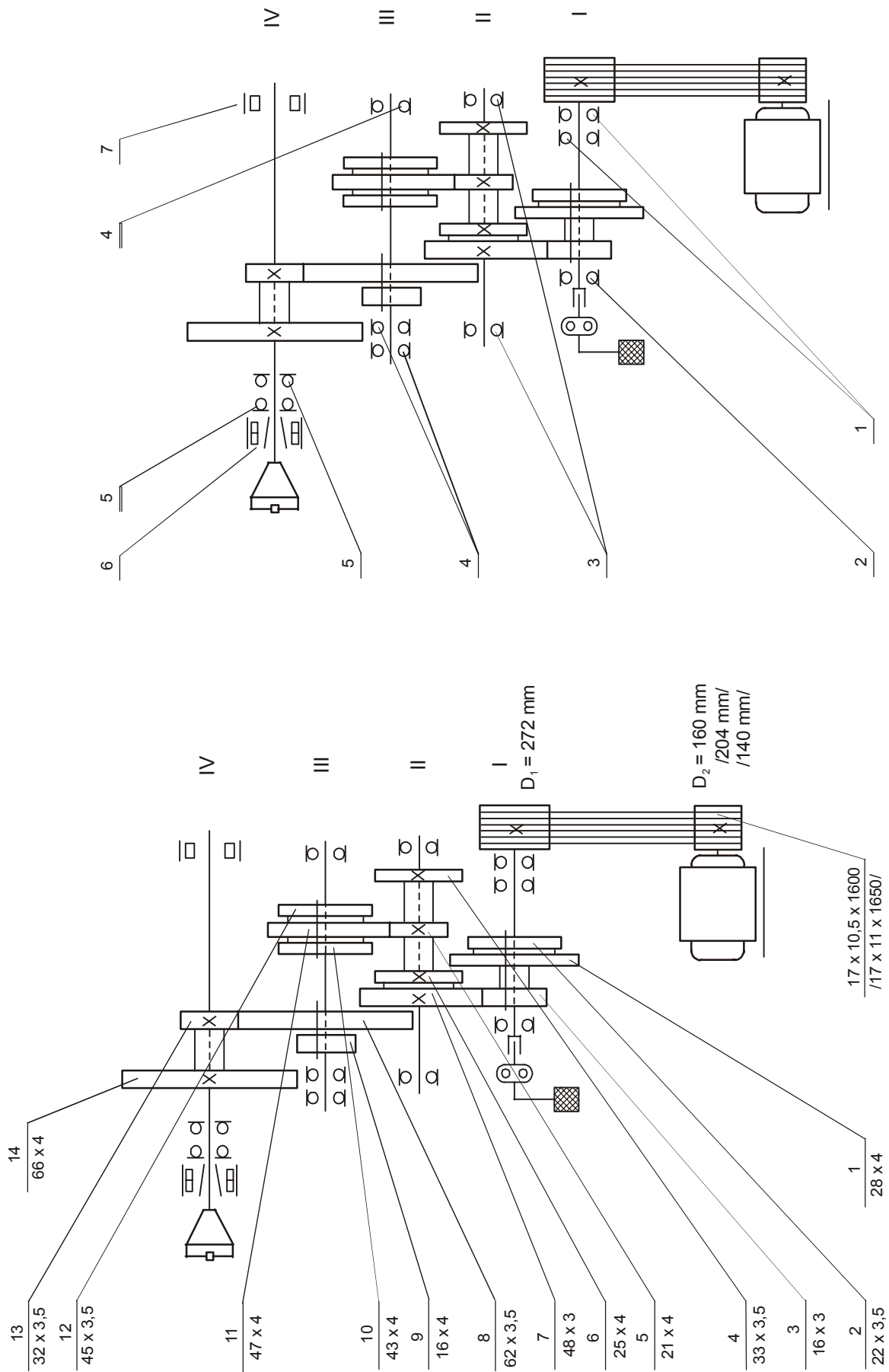

Fig. 13

Fig. 12

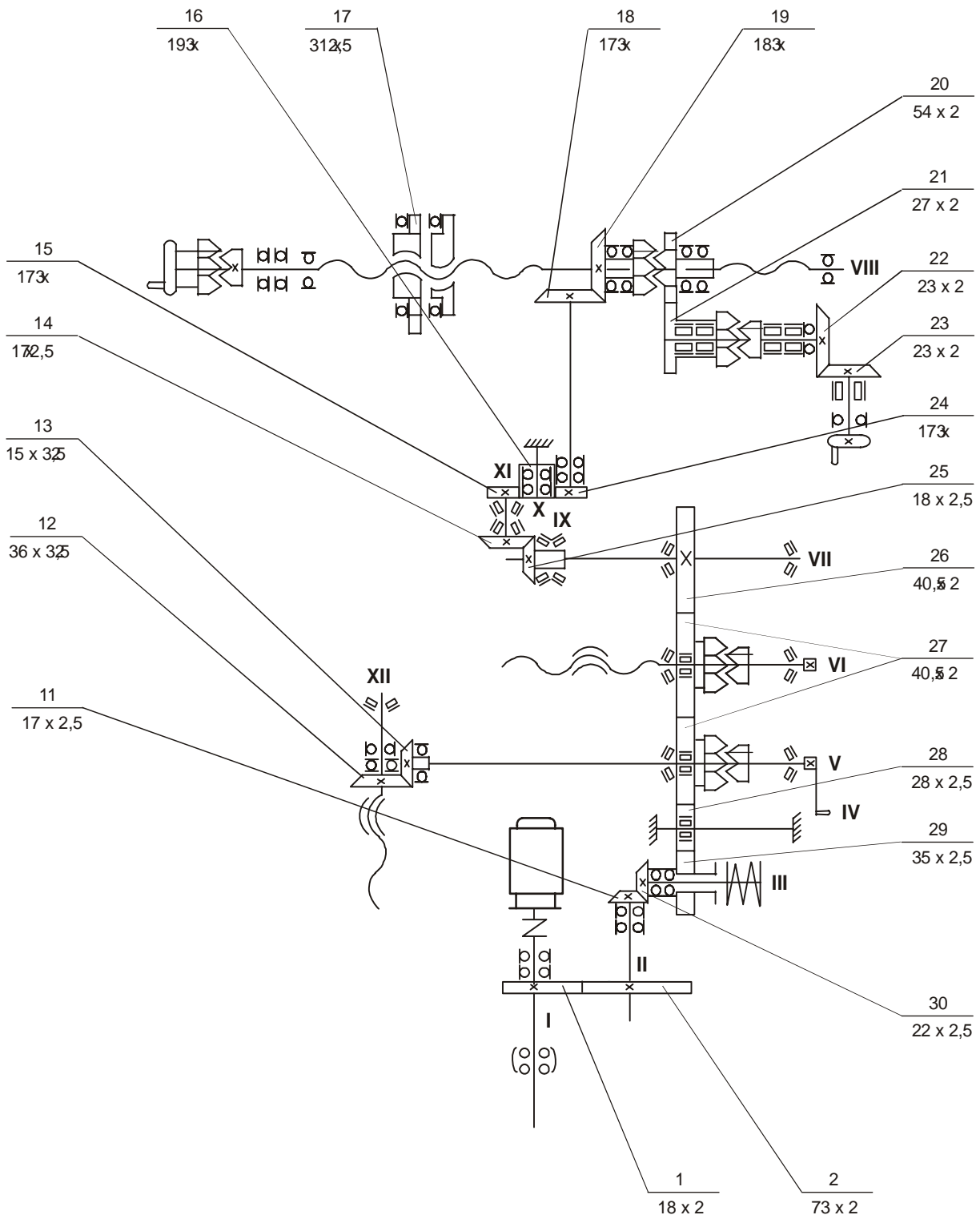

Fig. 14



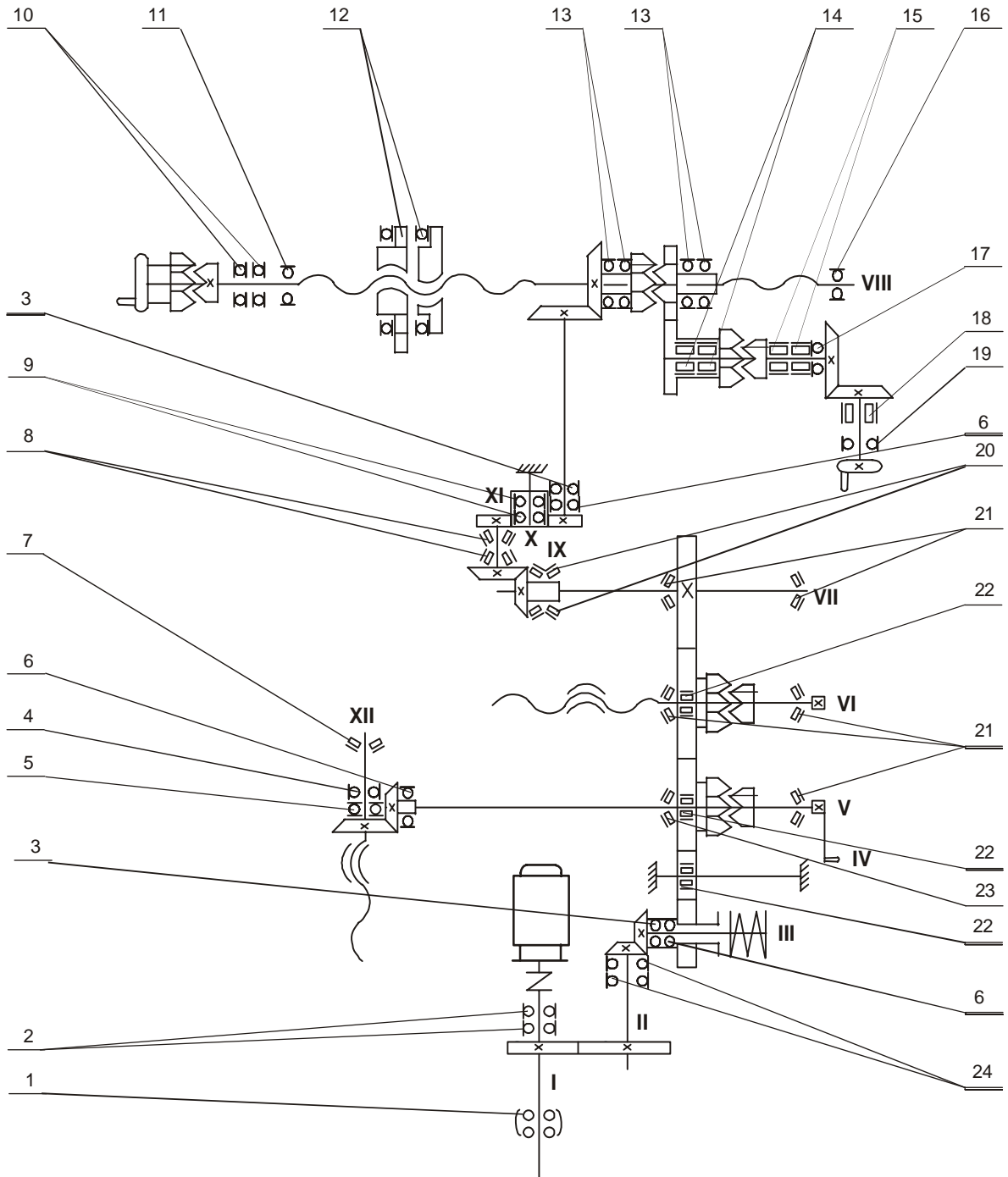
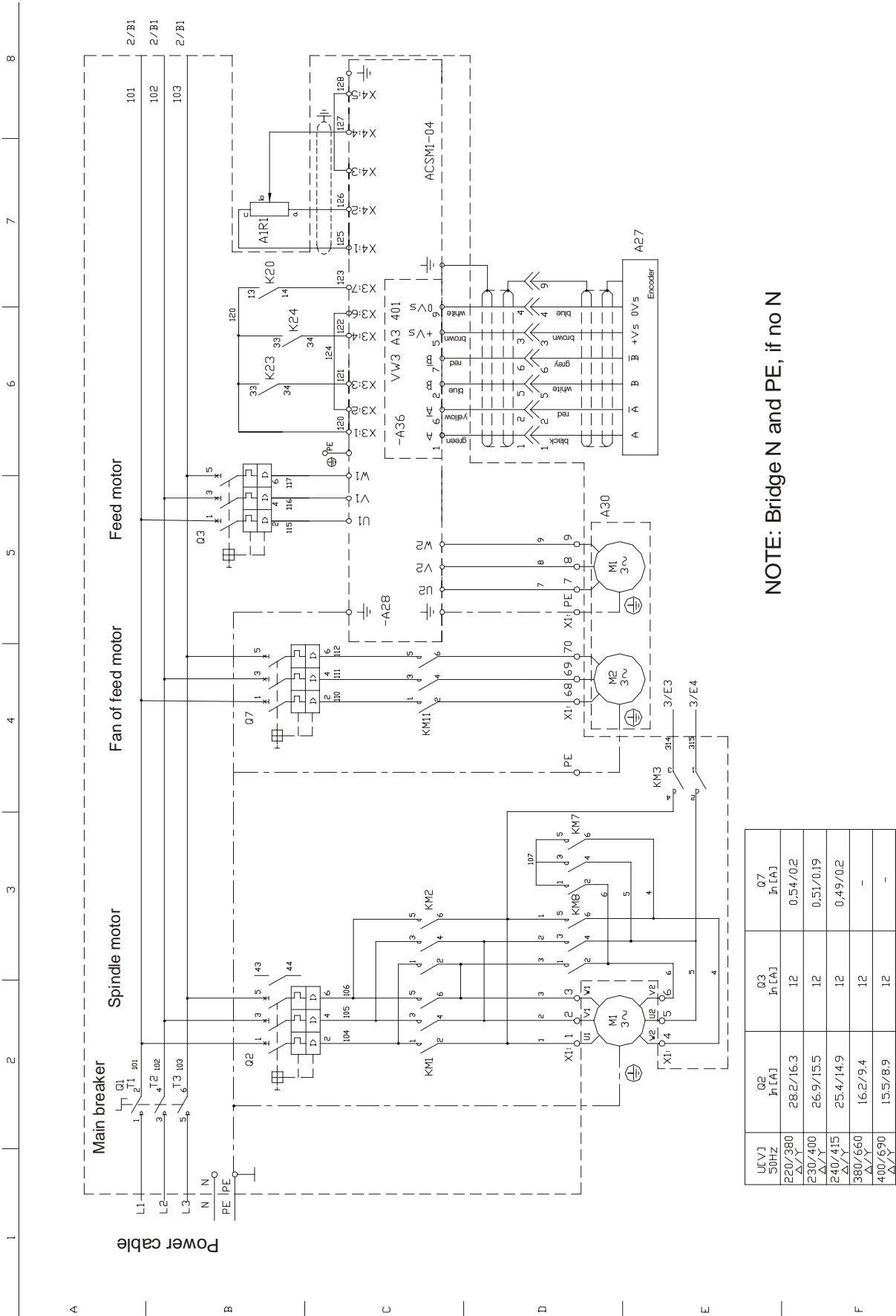

Fig. 15

# ELECTRIC CIRCUIT DIAGRAM



NOTE: Bridge N and PE, if no N

Fig. 16 /1

# ELECTRIC CIRCUIT DIAGRAM

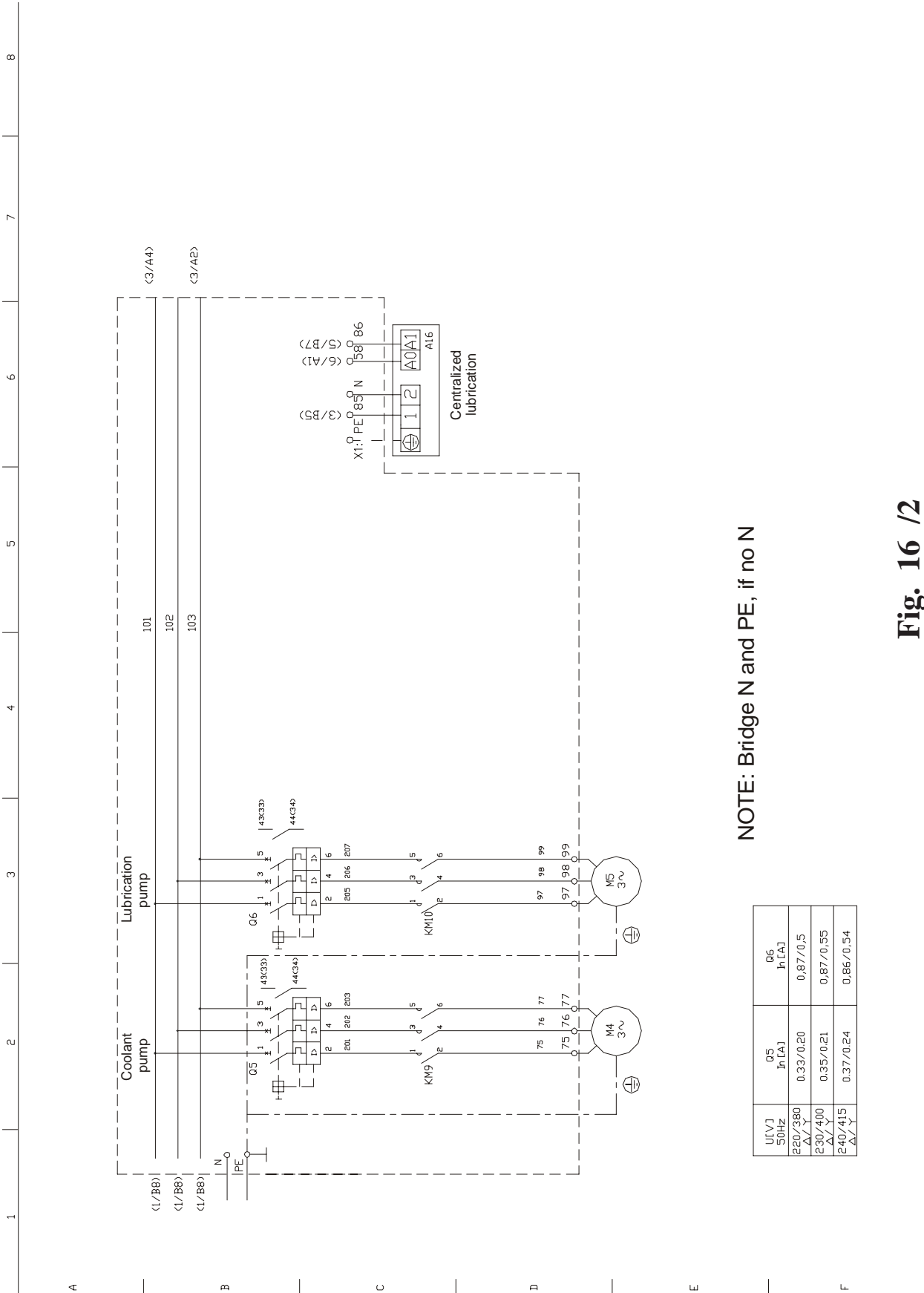

Fig. 16 /2

# ELECTRIC CIRCUIT DIAGRAM

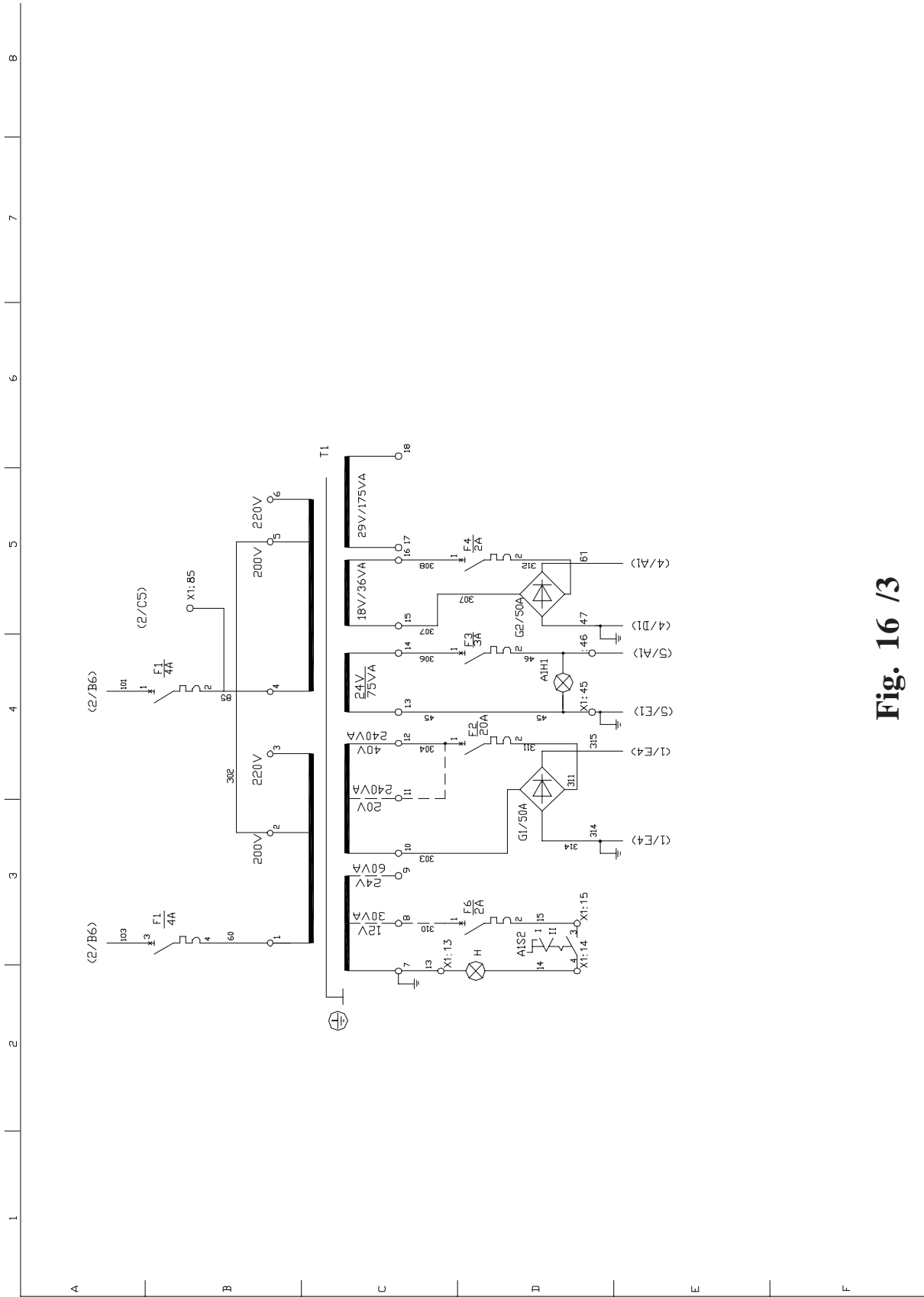
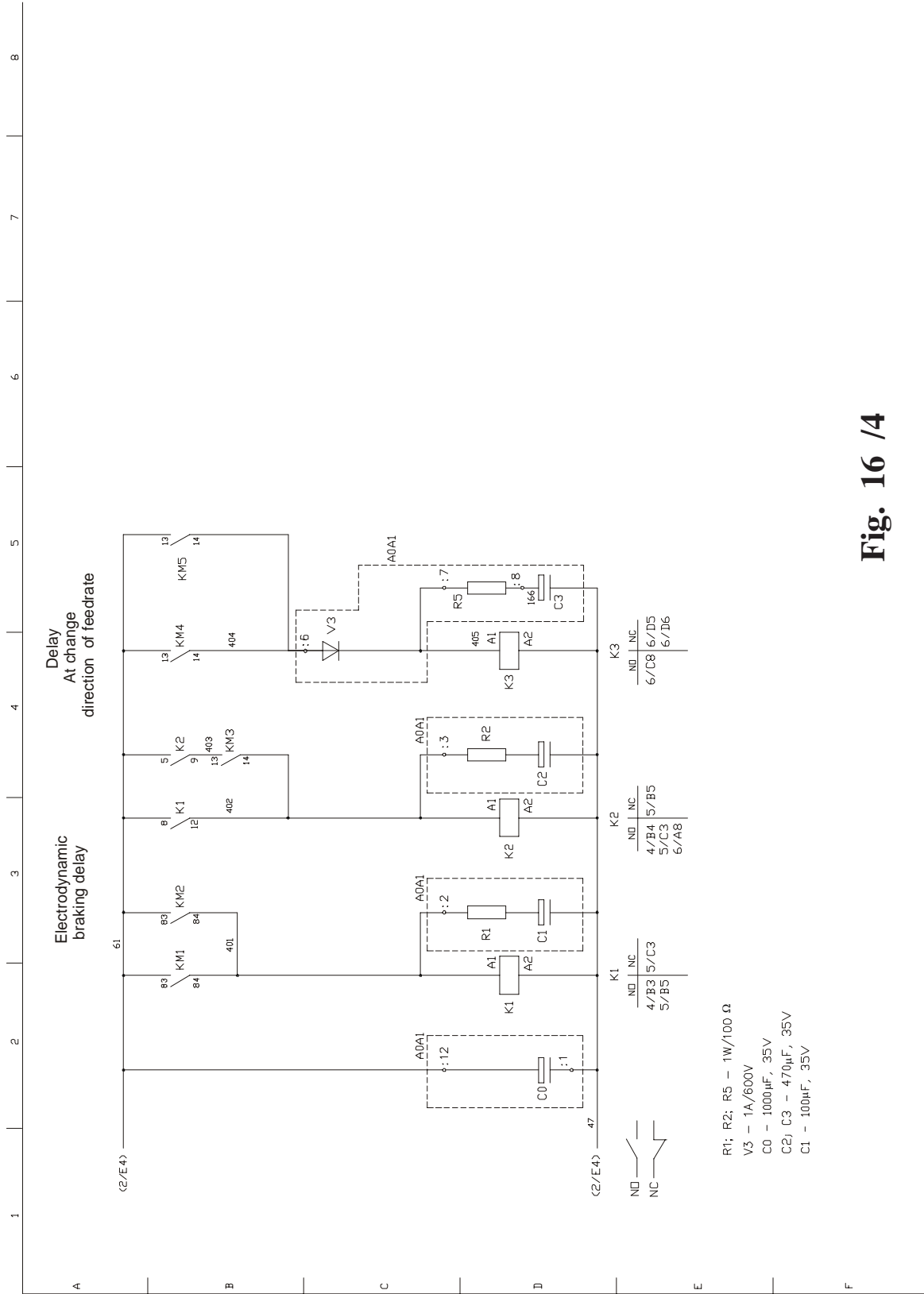

Fig. 16 /3

# ELECTRIC CIRCUIT DIAGRAM



**Fig. 16 / 4**

# ELECTRIC CIRCUIT DIAGRAM

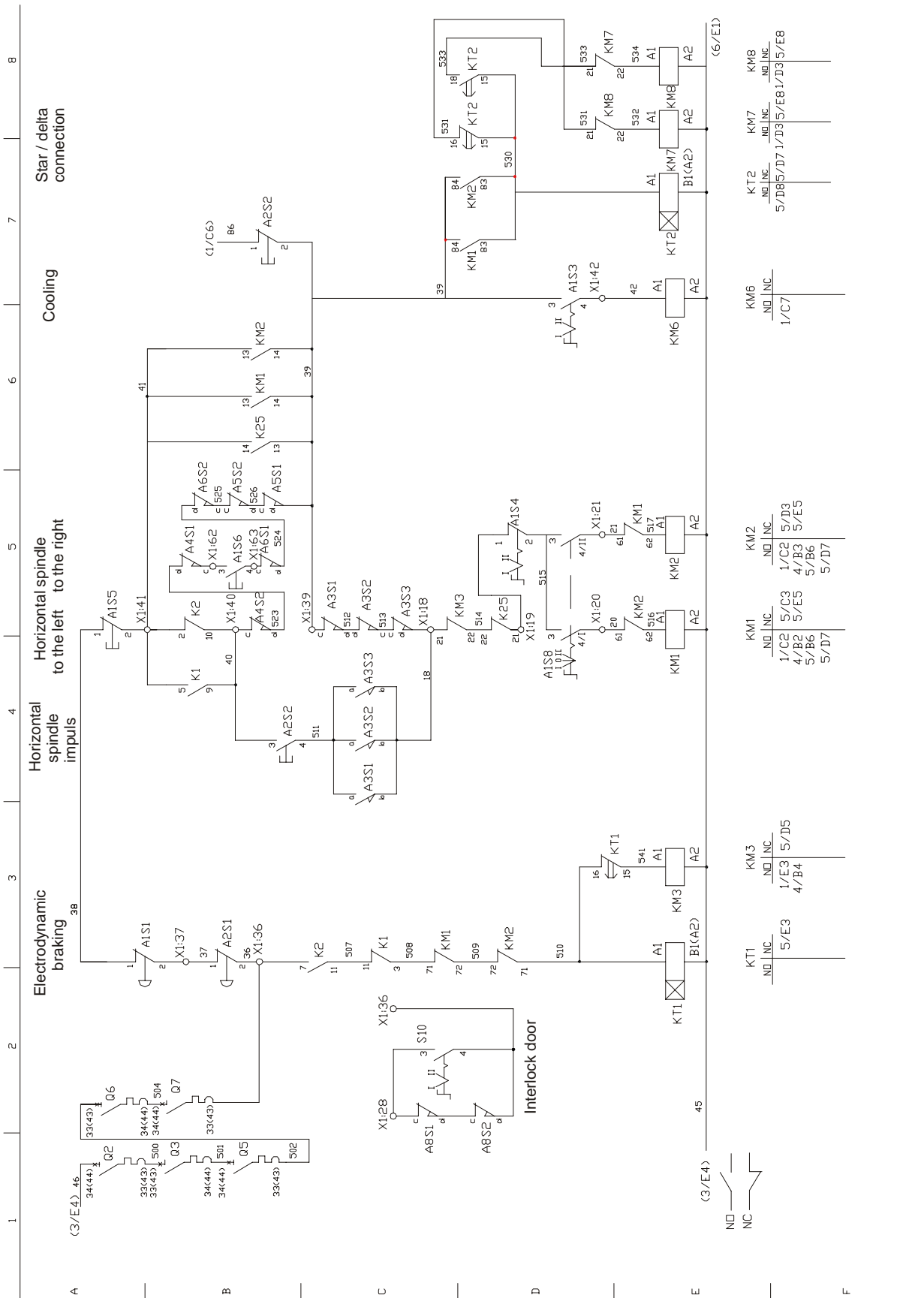

Fig. 16 /5

# ELECTRIC CIRCUIT DIAGRAM

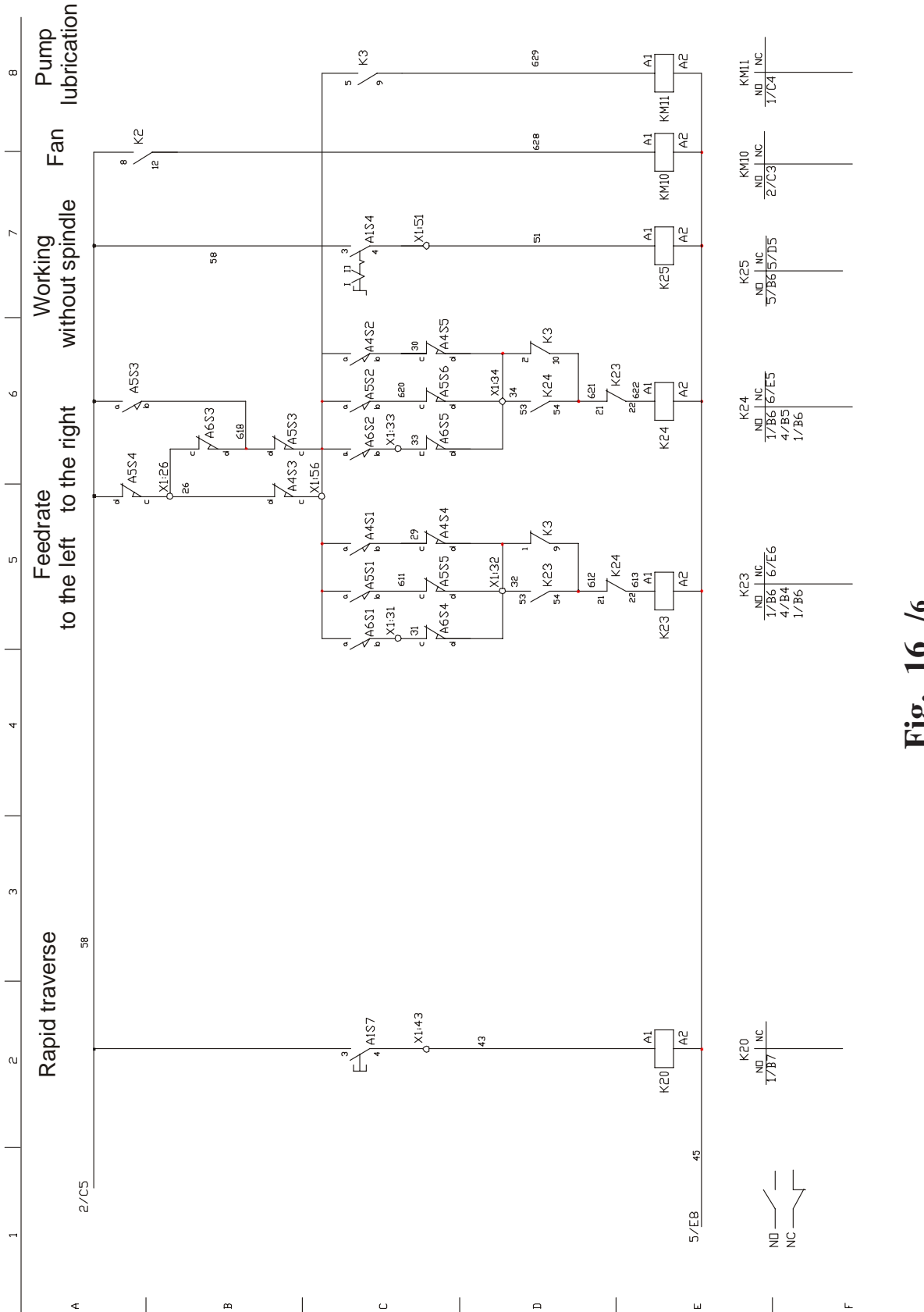

Fig. 16 /6

# WIRING DIAGRAM

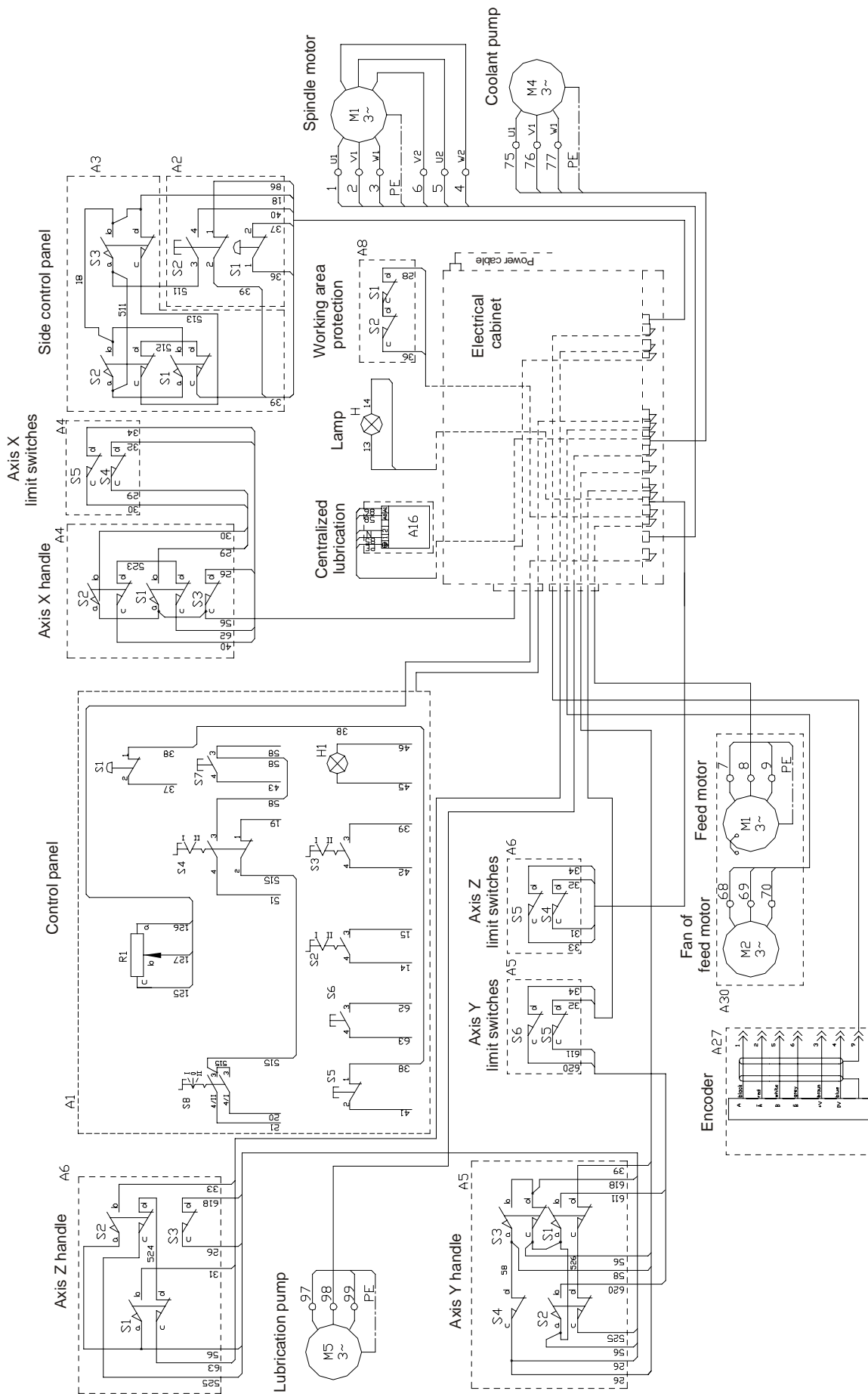

Fig. 17



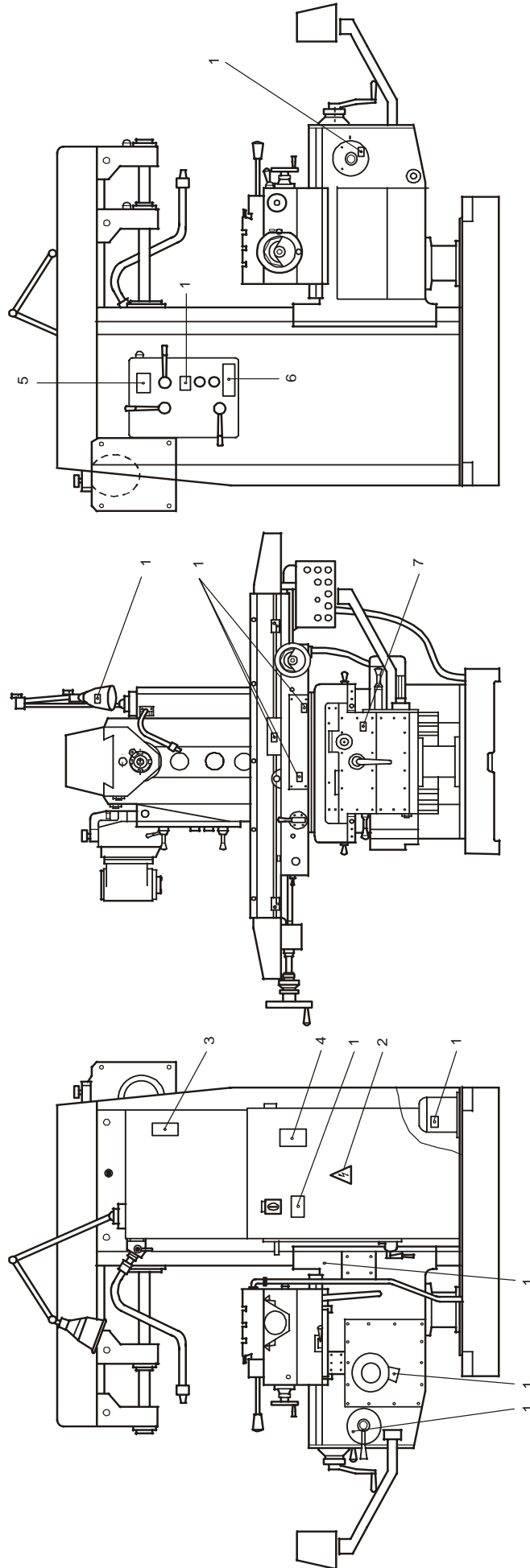

Fig. 18

PLATES AND WARNING LABELS DETAILS

No. 1



No. 2

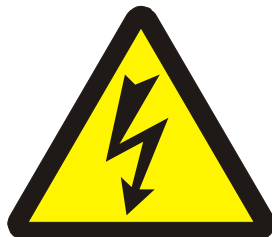

No. 5



No. 3

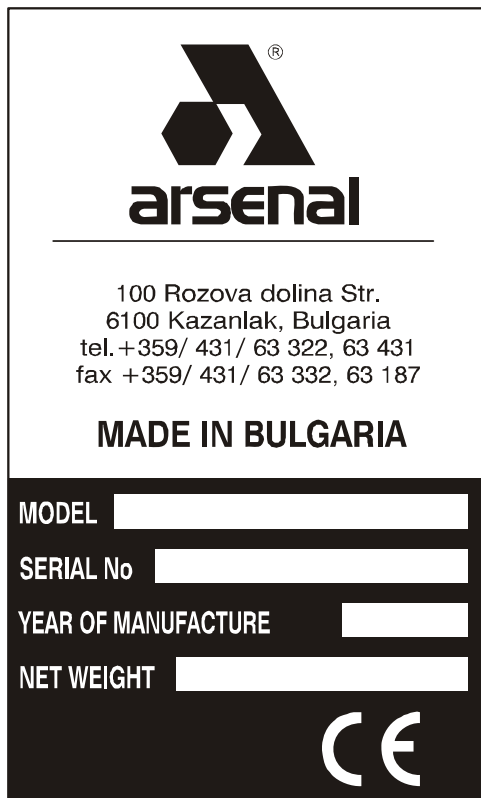

No. 4

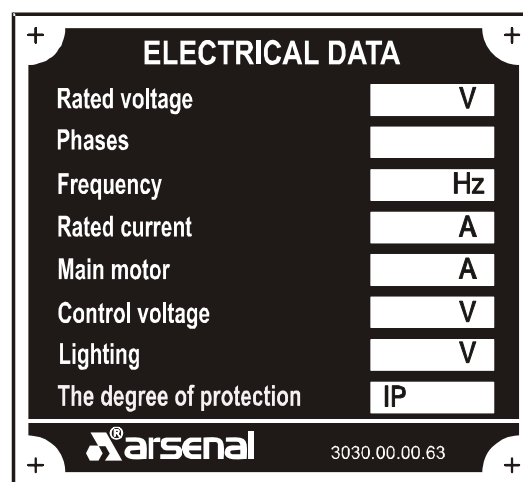

No. 7

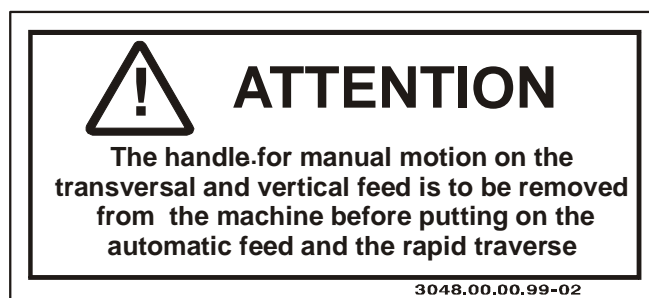

No. 6



Fig. 19

**NOTE:** If any of the plates or labels are removed and/or damaged they should be replaced.

## MAXIMUM LOAD AND SIZE OF MATERIAL TO BE MACHINED

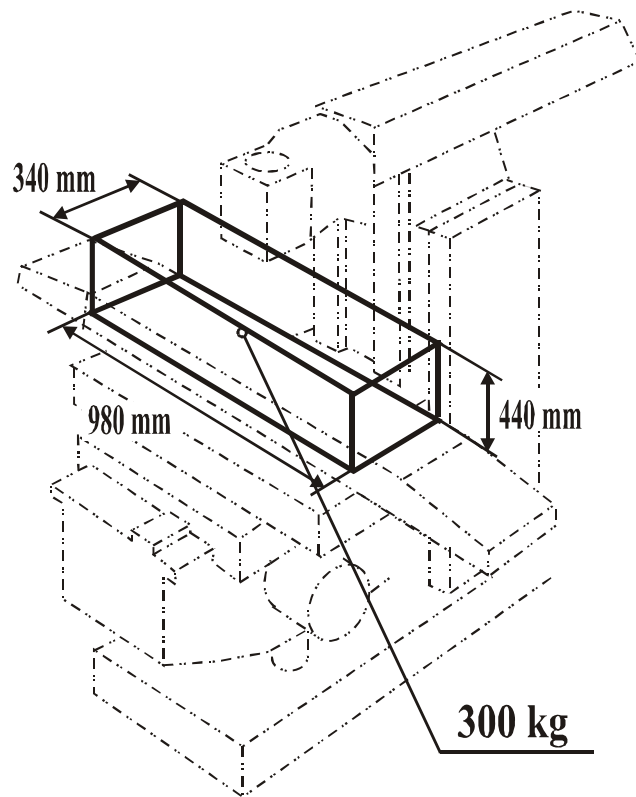

### Weight:

UDA 160 - 135 kg

KDM 320 - 74 kg

Vice - 44 kg

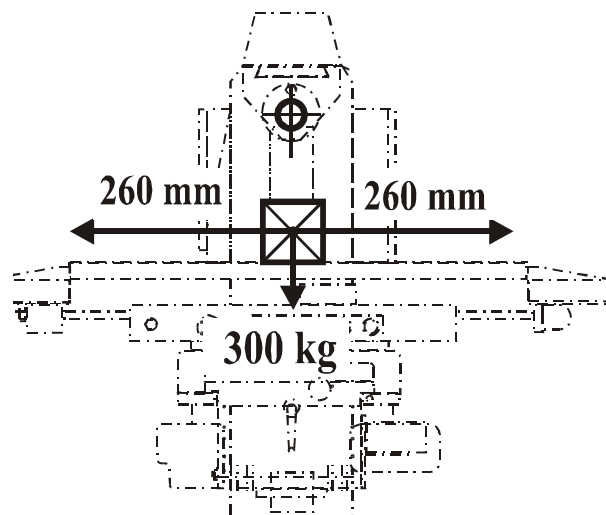

**Fig. 20**

Do not move the workpiece further from the centre of gravit than indicated above. The weights of UDA 160, KDM 320, Vice CMCB 200/250 and clamping fixture are included in the specified maximum weight of workpiece.

## OPERATOR'S WORKING POSITION ON THE MACHINE

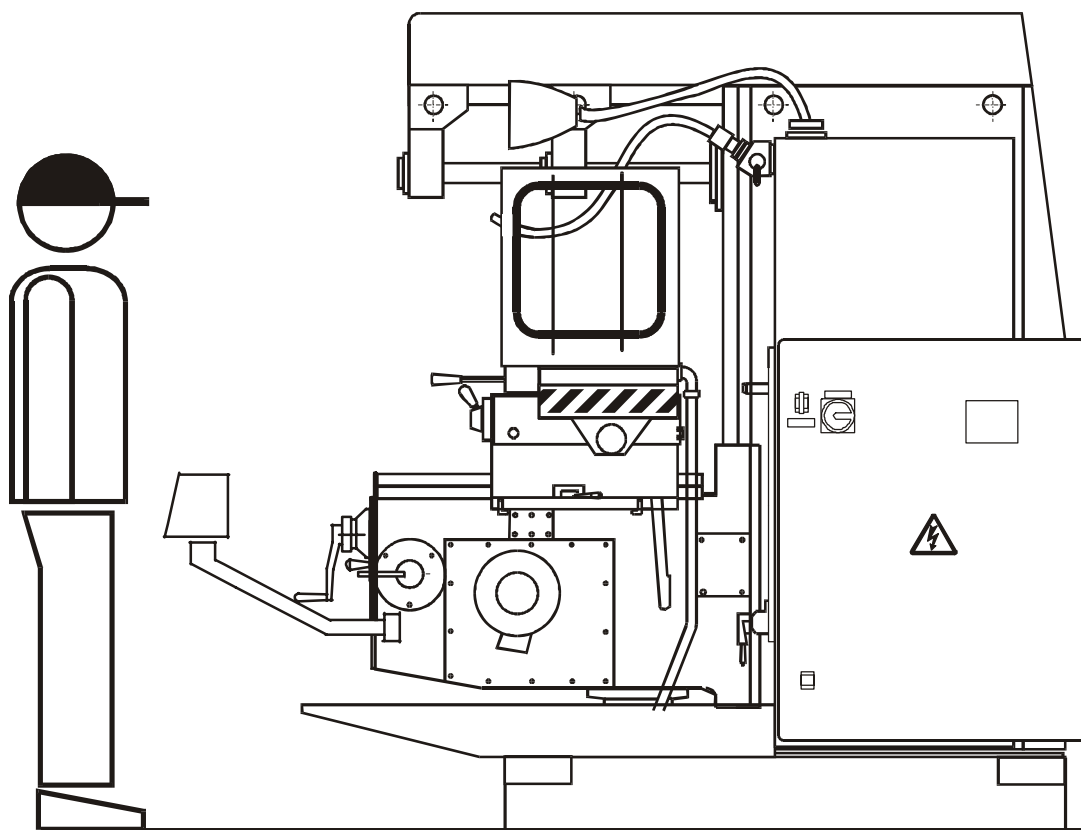
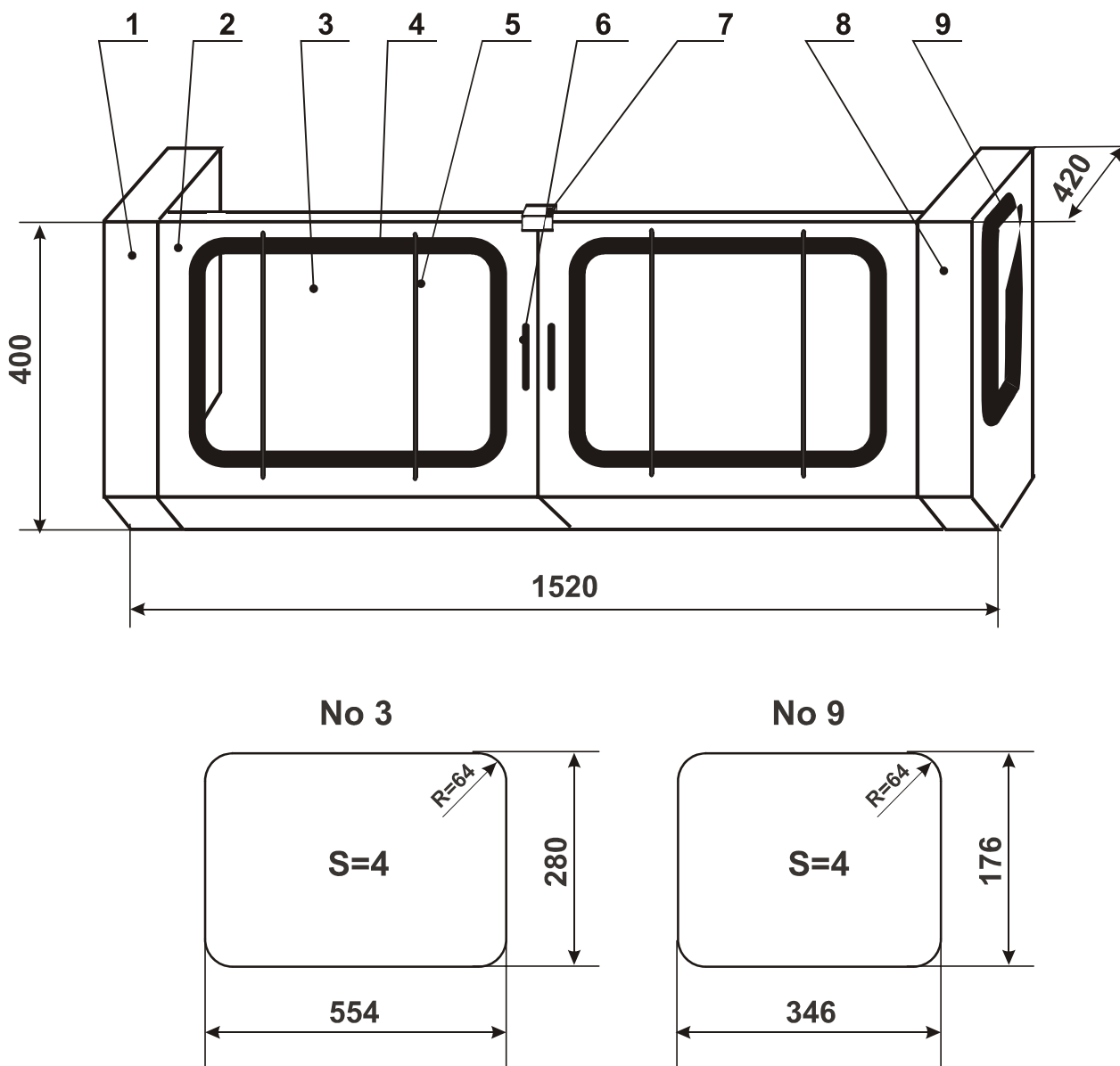

Fig. 21

**SAFETY GUARD**



**Fig. 22**

1. Safety guard left side
2. Door
3. Window
4. Support Seal
5. Support brackets
6. Locking handle
7. Lock
8. Safety guard right side
9. Window

### MARKING ON THE PACKING

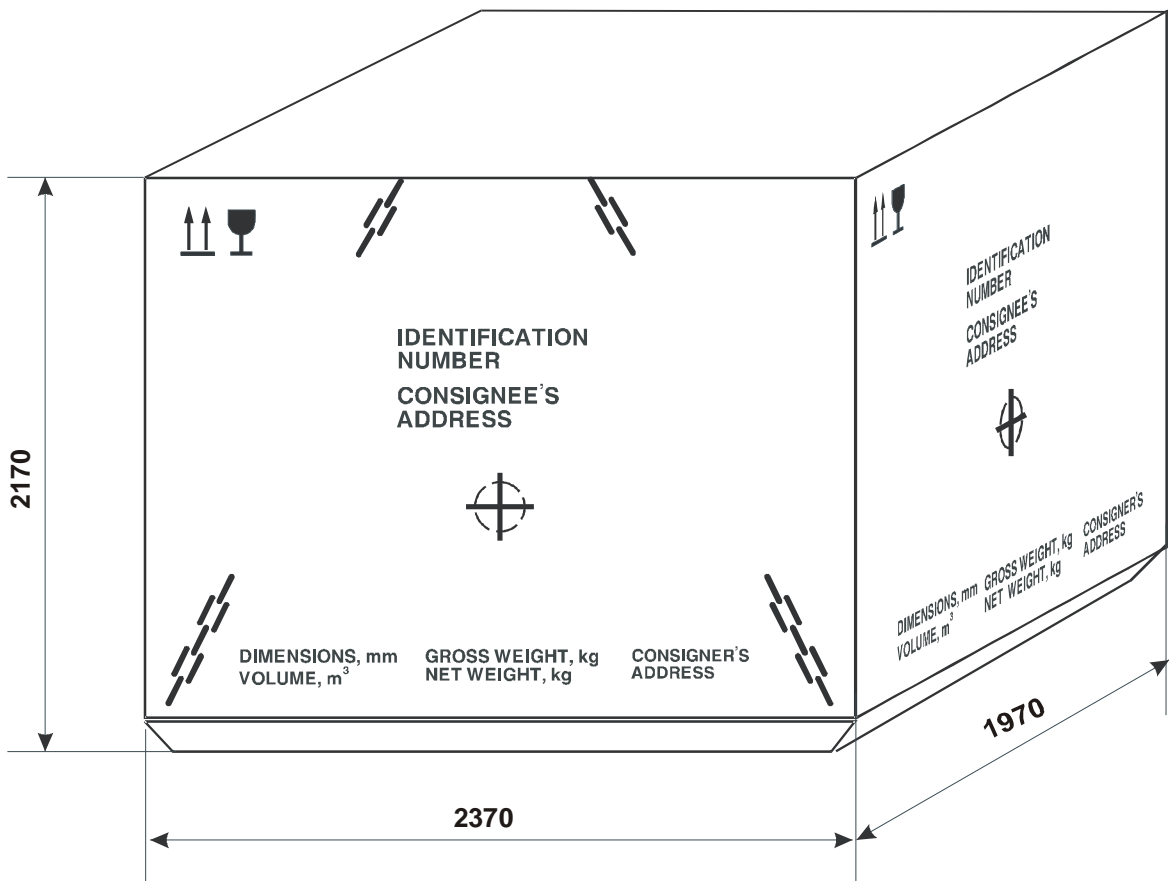

Fig. 23

### DIGITAL READOUT SYSTEM

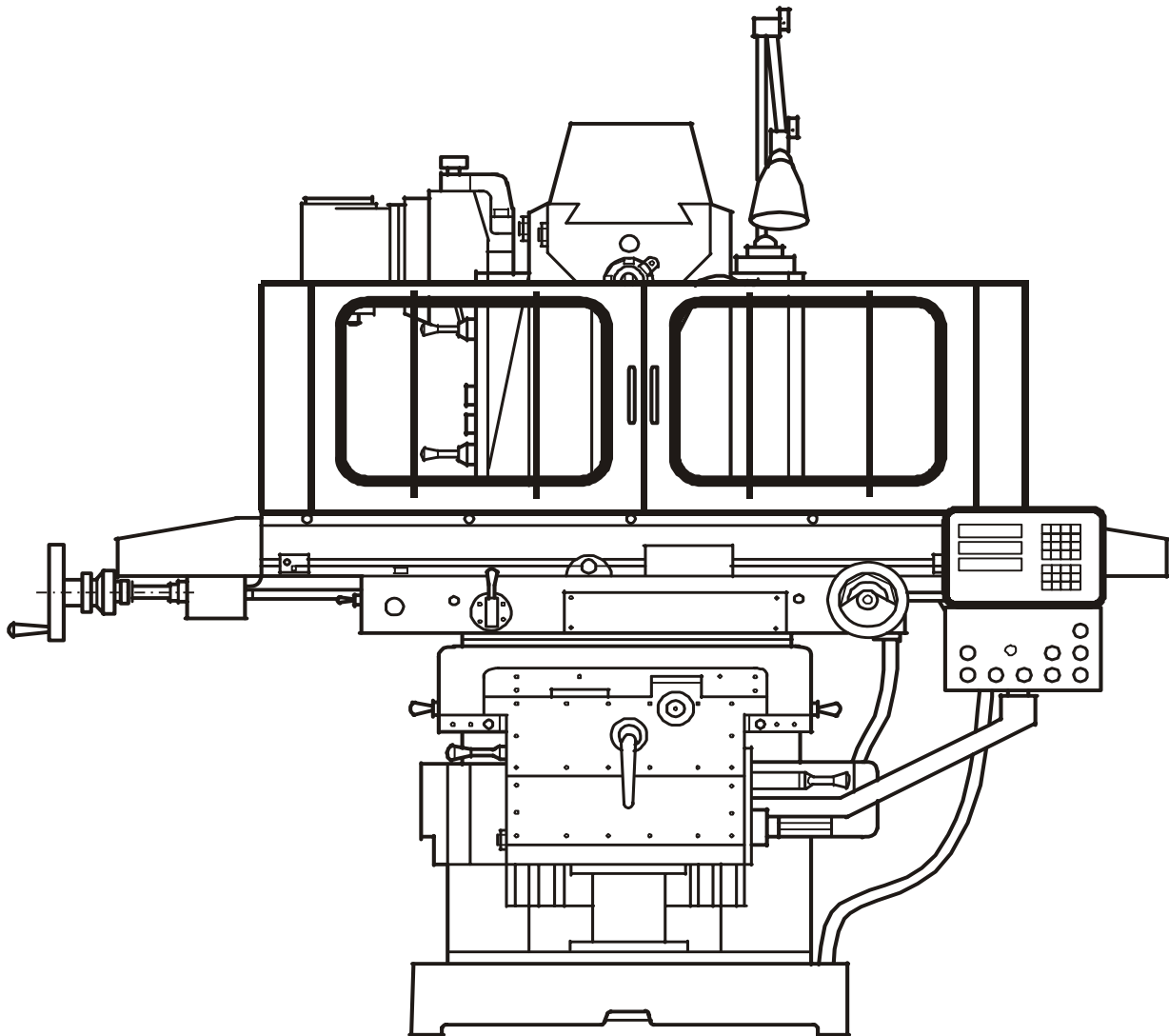
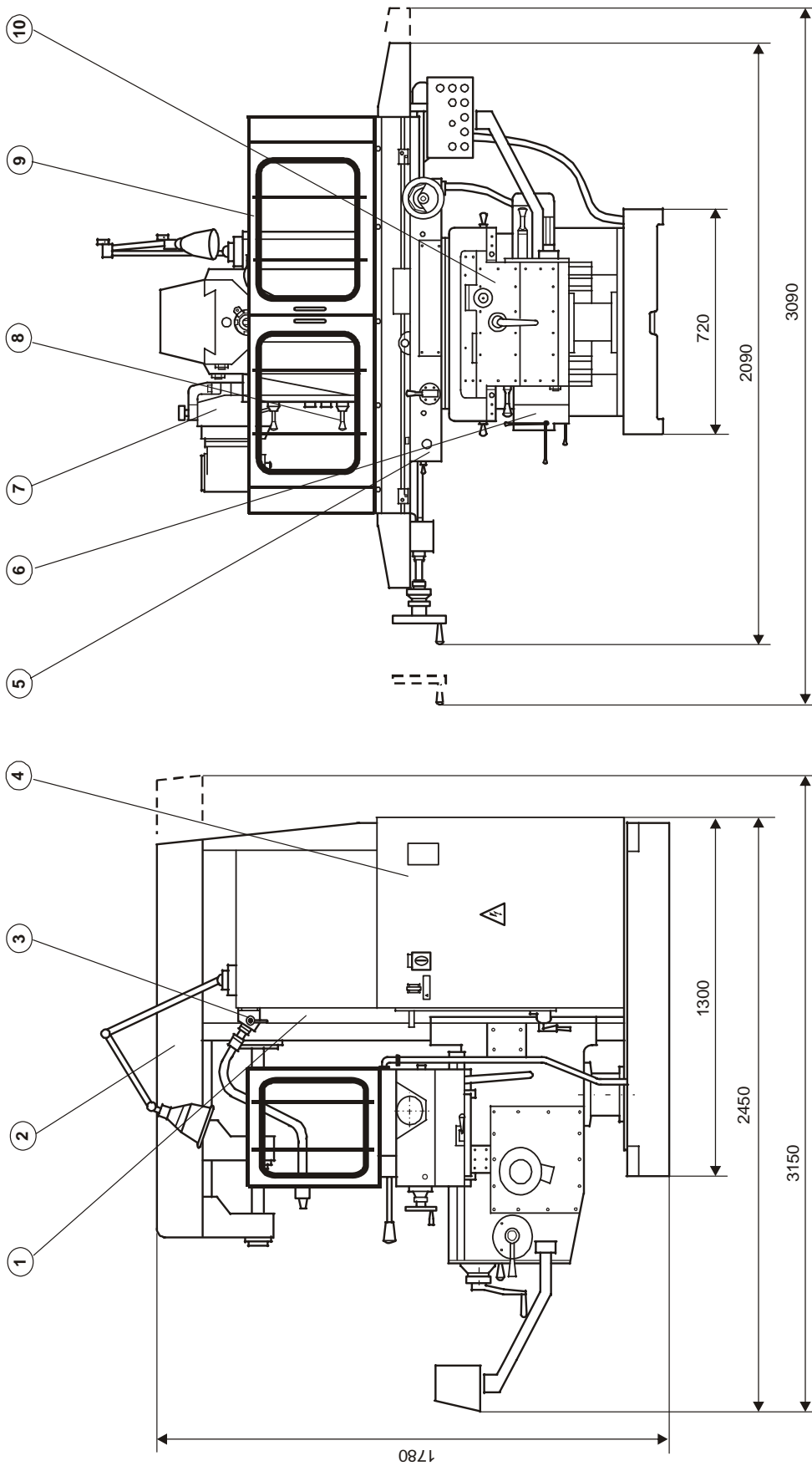

Fig. 24

GENERAL VIEW



- 6. Feed gear box
- 7. Accessories
- 8. Spindle gear box changer
- 9. Safety guard
- 10. Knee

- 1. Body, base, spindle box
- 2. Yoke, brackets, arbors
- 3. Cooling system
- 4. Electric system
- 5. Slide, saddle and working table

Fig. 25